



Code Compliance Research Report

CCRR-0105

Subject to Renewal: 02/18/2018
Visit www.ati-es.com for current status

Issued: 02/23/2016
Page 1 of 6

Nebraska Plastics, Inc.
700 West Highway 30
Cozad, Nebraska 69130
(800) 662-2936

www.fencesbycountryestate.com

1. Subject

Country Estate Railing System

Also, identified as:

Country Estate Handrail or EZ Rail

2. Research Scope

2.1 Building Codes:

2012 International Building Code (IBC)
2012 International Residential Code (IRC)

2.2 Properties:

Structural performance
Durability
Surface Burning

3. Description

3.1 General – *Country Estate Railing Systems* are guards under the definition of the referenced codes intended for use on elevated walking areas in buildings and walkways as required by the codes.

3.2 Materials and Processes – Railing systems are an assemblage of extruded and molded components utilizing Poly Vinyl Chloride (PVC) material with aluminum reinforcements and metal mounting brackets. Vinyl components are produced in four colors; white, oti tan, gray, almond and adobe. All systems consist of the following components:

3.2.1 Top rails are either a T-Rail 3.5" wide by 3.5" tall or a rectangular profile 2" wide by 3.5" tall (See Figure 1).

3.2.2 Bottom rails in all systems are a 2" wide by 3.5" tall rectangular profile.

3.2.3 Balusters are provided in four styles. Three picket styles are 1.5" square, 1" by 2" rectangular, or 1.5" round throughout their length. The fourth style is 1.5" square at the ends and

thermo-formed to a turned spindle through the middle region of its length. (See Figure 2).

3.2.4 Railing reinforcement inserts are 6063-T6 aluminum formed by extrusion. Two H-Channel inserts are used interchangeably (See Figure 5).

3.3 Guards are produced for installed heights equal to 42" and 36" from the top of the walking surface to the top of the top rail.

3.3.1 42" high guards utilize extruded aluminum inserts for reinforcement in the top rails. 42" high guards are recognized for use in all residential use groups.

3.3.2 36" high guards utilize extruded aluminum inserts for reinforcement in the top rail only. 36" high guards are recognized for use only in One- and Two-Family Dwellings.

3.4 Top and bottom rails are connected to supports with brackets as shown in Figure 3 and Figure 4.

3.5 Railing systems are secured to and supported by conventional wood posts. A co-extruded PVC post sleeve that is non-structural is provided as a cladding over conventional 4x4 wood posts. Code compliance assessment of conventional wood posts is not within the scope of this report. See Figure 6.

4. Performance Characteristics

4.1 *Country Estate Railing Systems* described in this report have demonstrated the capacity to resist the design loads specified in Chapter 16 of the IBC, as well as Section R301 of the IRC when tested in accordance with ICC-ES AC174.

4.2 Materials used to produce the railings are deemed equivalent to preservative treated or naturally durable wood for resistance to weathering effects, decay, and attack from termites.

4.3 Structural performance has been demonstrated for a temperature range from -20°F to 125°F.

4.4 The PVC material used in the guardrail system has a flame spread index not greater than 200 when tested in accordance with ASTM E 84,

as required by the reference criteria, ICC-ES AC174.

5. Installation

Installation shall be in accordance with the manufacturer's installation instructions and this report. Where differences occur between this report and the manufacturer's installation instructions, this report shall govern.

5.1 Railing assemblies consist of top and bottom rails with pre-routed holes to receive balusters. Aluminum railing reinforcements are inserted in the rails during assembly as specified for the series/model and length (See Table 1).

5.2 Rail brackets are secured to the support posts and rails as described in Table 3.

5.3 The wood in the supporting structure including support posts shall have a specific gravity of 0.50 or greater (Southern Yellow Pine or better) and a minimum thickness to allow full penetration of the bracket mounting screws.

6. Supporting Evidence

6.1 Manufacturer's drawings and installation instructions.

6.2 Reports of testing and engineering analysis demonstrating compliance with ICC-ES AC174, Acceptance Criteria for Deck Board Span Ratings and Guardrail Systems (Guards and Handrails), revised February 2014; and ASTM D 7032-08, Standard Specification for Establishing Performance Ratings for Wood-Plastic Composite Deck Boards and Guardrail Systems (Guards or Handrails).

6.3 Quality control manual in accordance with ICC-ES AC10, Acceptance Criteria for Quality Control Manuals, June 2014.

7. Conditions of Use

The guard assemblies identified in this report are deemed to comply with the intent of the provisions of the referenced building codes subject to the following conditions:

7.1 Guardrail systems recognized in Table 2 are limited to exterior use in all construction types where wood is permitted in accordance with Section 1406.3 of the IBC and in One and Two Family Dwellings regulated by the IRC. Guards recognized in Table 1 are further limited to use in One- and Two-Family Dwellings (IRC).

7.2 Conventional wood supports including support posts for guards are not within the scope of this report and are subject to evaluation and approval by the building official. Supports must satisfy the design load requirements specified in Chapter 16 of the IBC and must provide suitable material for anchorage of the rail brackets (See 5.3 under "Installation"). Where required by the building official, engineering calculations and details prepared by a licensed design professional shall be provided.

7.3 Only those types of fasteners and fastening methods described in this report have been evaluated for the installation of the *Country Estate Railing Systems*; other methods of attachment are outside the scope of this report.

7.4 Compatibility of fasteners, post mount brackets, and other metallic components with the supporting structure including chemically treated wood is not within the scope of this report.

7.5 *Country Estate Railing Systems* are manufactured in Cozad, Nebraska in accordance with an approved quality control system with inspections by Architectural Testing (IAS AA-676).

8. Identification

Country Estate Railing Systems produced in accordance with this report shall be identified with labeling on the individual components or the packaging that includes the following information:

8.1 The following statement: "See CCRR-0105 at www.ati-es.com for uses and performance levels."

8.2 The phrase: "For Use in One- and Two-Family Dwellings Only" for guardrail systems identified in Table 1.

8.3 The Architectural Testing Code Compliance Research Report mark and number (CCRR-0105).

9. Code Compliance Research Report Use

9.1 Approval of building products and/or materials can only be granted by a building official having legal authority in the specific jurisdiction where approval is sought.

9.2 Code Compliance Research Reports shall not be used in any manner that implies an endorsement of the product by Architectural Testing.

9.3 Reference to the Architectural Testing internet web site address at www.ati-es.com is recommended to ascertain the current version and status of this report.

Table 1 – Guardrail Systems for IRC Occupancies ⁽¹⁾

Railing Style	Type	Maximum Guardrail Dimensions ⁽²⁾	Bracket	Aluminum Reinforcements	
				Top Rail	Bottom Rail
T-Rail	Level	120" x 36"	Zinc Die-Cast or PVC Molded	Aluminum H-Channel	None
		96" x 36"	LMT #1522		
2" x 3-1/2" Rail	Level	120" x 36"	Zinc Die-Cast or PVC Molded	Aluminum H-Channel	None
		96" x 36"	LMT #1521		

⁽¹⁾ The use of these products shall be limited to exterior use as a guard system for balconies and porches for one-and two family dwellings of Type V-B (IBC) construction and structures constructed in accordance with the IRC.

⁽²⁾ Railing lengths are clear length between supports. Railing height is installed height from walking surface to top of top rail.

Table 2 – Guardrail Systems for IBC Occupancies

Railing Style	Type	Maximum Guardrail Dimensions ⁽¹⁾	Bracket	Aluminum Reinforcements	
				Top Rail	Bottom Rail
T-Rail	Level	96" x 42"	Zinc Die-Cast, PVC Molded, or LMT #1522	Aluminum H-Channel	None
2" x 3-1/2" Rail	Level	96" x 42"	Zinc Die-Cast, PVC Molded, or LMT #1521	Aluminum H-Channel	None

⁽¹⁾ Railing lengths are clear length between supports. Railing height is installed height from walking surface to top of top rail.

Table 3 – Fastener Schedule

Brackets	Rail Bracket to Post		Rail Bracket to Rail	
	Fastener	Qty	Fastener	Qty
Zinc Die-Cast	#10 by 2" long stainless steel wood screws	6	#10 by 1" long stainless steel sheet metal screws	2
PVC Molded				
LMT Brackets	#10 by 1-1/2" long stainless steel, pan head, self-starting screws	4	#10 by 1" long stainless steel, pan head, self-starting screws	4

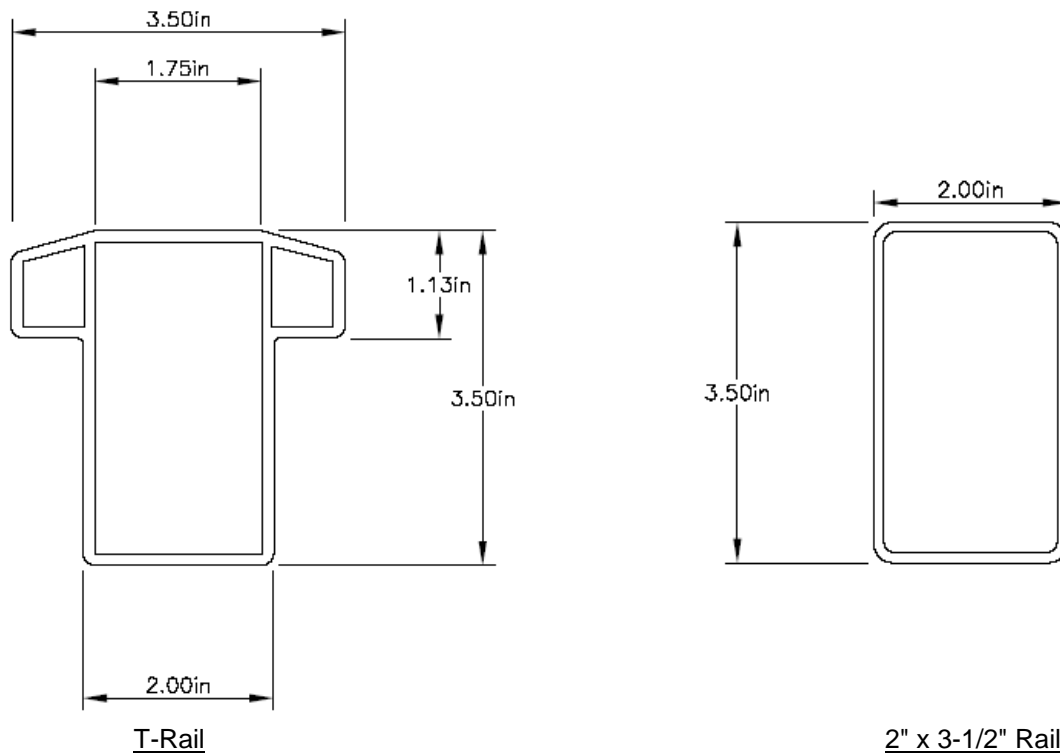
Figure 1 - PVC Rail Profiles

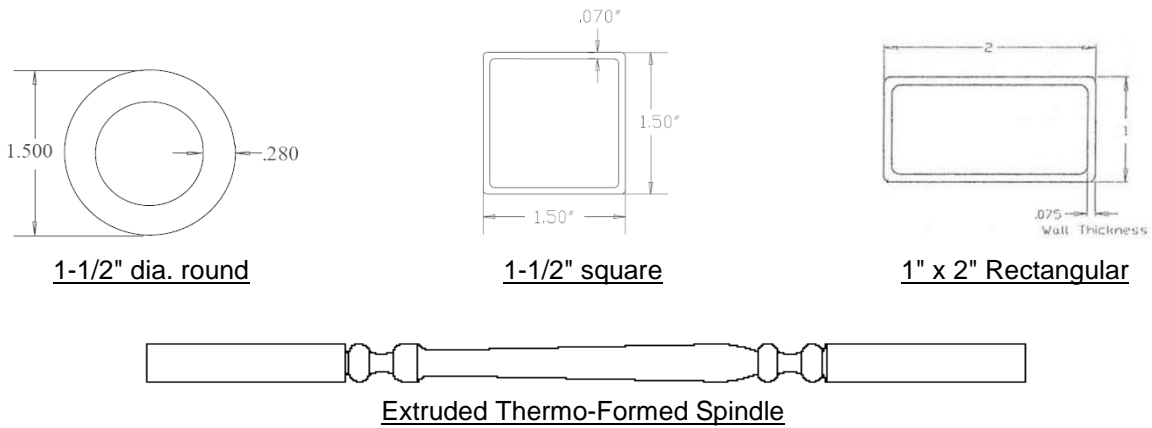
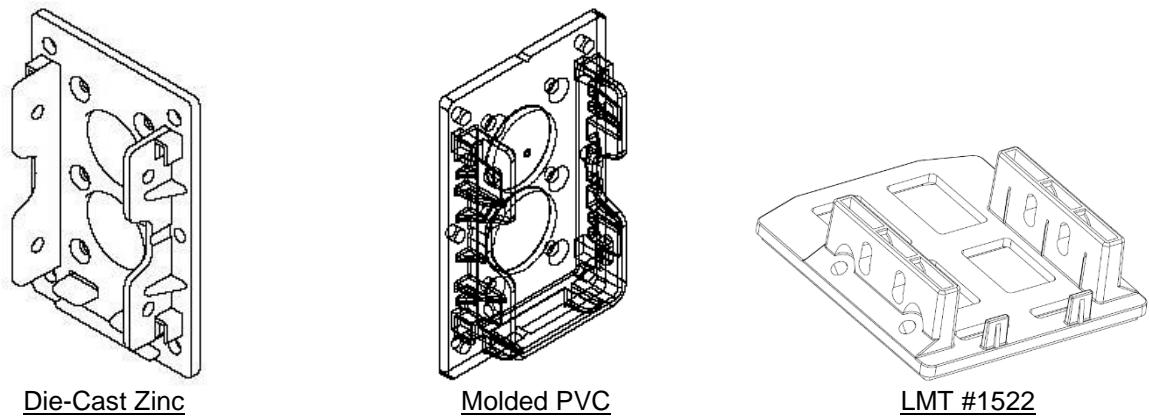
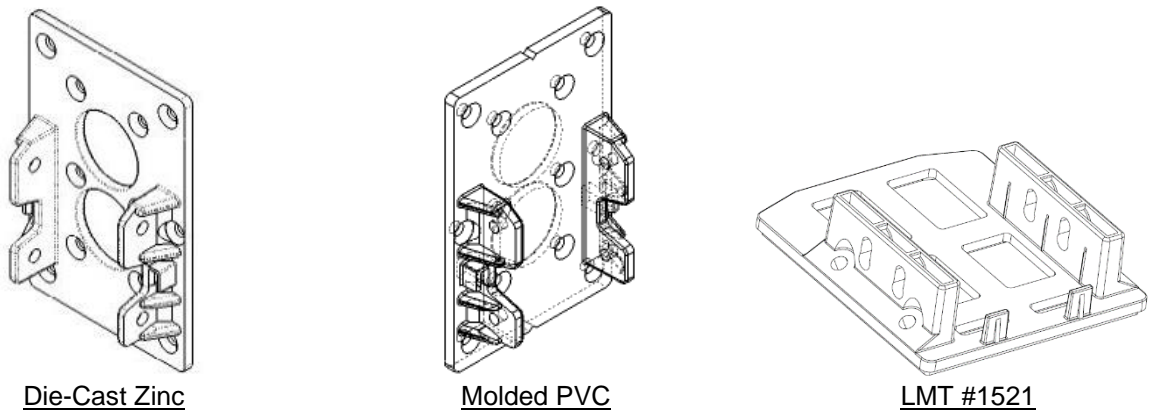
Figure 2 – Balusters

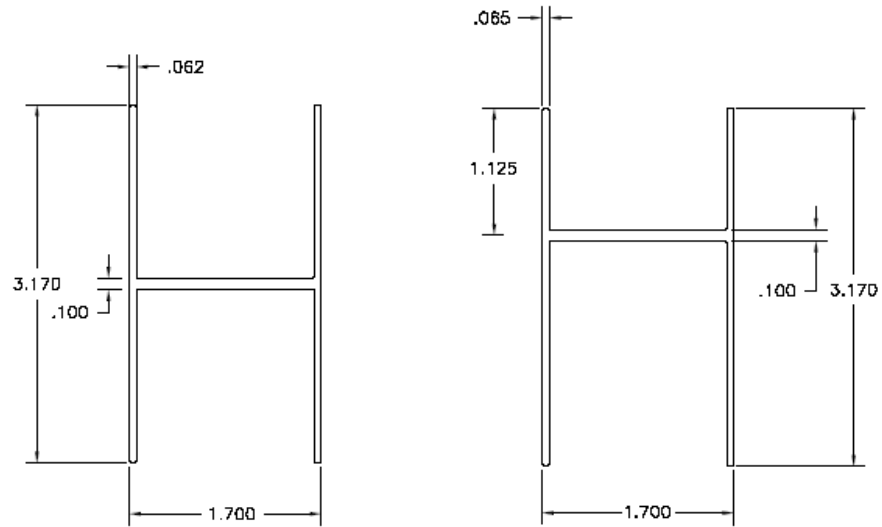
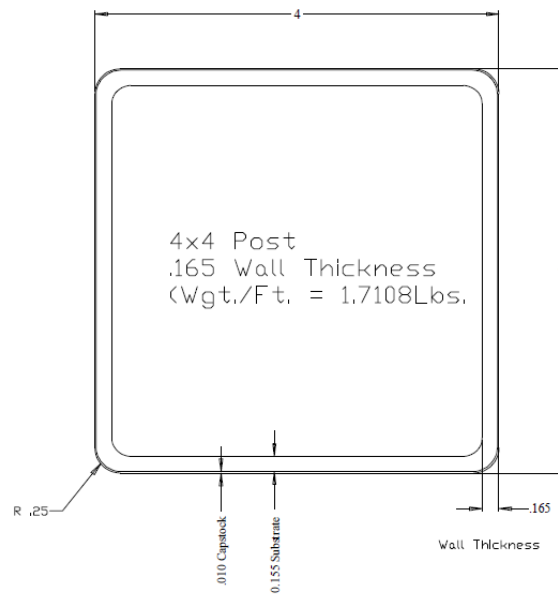
Figure 3 - 2" x 3-1/2" Rail Brackets

Figure 4 - T-Rail Brackets

Figure 5 - Aluminum H-Channel

Figure 6 - 4x4 Co-Extruded Post Sleeve