



Subject to Renewal: 04/15/2018

Visit www.ati-es.com for current

Issued: 04/06/2017

Page 1 of 23

Maine Ornamental LLC
933 U.S. Route 202
Greene, ME 04236
(207) 946-2410

www.ufpi.com

1.0 Subject

Deckorators® Aluminum Railing Systems

2.0 Research Scope

2.1. Building Codes:

2015 International Building Code (IBC)

2015 International Residential Code (IRC)

2012 International Building Code (IBC)

2012 International Residential Code (IRC)

The year of referenced standards applies to the 2015 IBC & IRC. When different, the year of referenced standards applicable to the 2012 IBC & IRC will follow the reference in parenthesis.

2.2. Properties:

Structural Performance

3.0 Description

3.1. General – *Deckorators® guardrail systems* are guards or guardrails under the definitions of the referenced codes. It is intended for use at or near the open sides of elevated walking areas of buildings and walkways as required by the codes.

3.2. Guard Assemblies – Guards are provided as level guards for level walking areas such as decks, balconies and porches and sloped guards for open sides of stairways.

3.2.1. Level guards are provided with rail lengths up to 96 inches in length (measured between the inside of support posts) and an installed height of up to 46 inches measured from the top of the upper rail to the walking surface. See Table 1 for qualified lengths and configurations.

3.2.2. Stair guards are provided with rail lengths up to 94 inches measured along the sloping length between the inside of supports and an installed height of up to 46 inches measured vertically from the top of the upper rail to the leading edge of the stair tread or landing. See Table 1 for qualified lengths and configurations.

3.3. Materials and Processes - *Deckorators® guardrail systems* are an assemblage of an aluminum upper and lower rail, aluminum or glass vertical balusters, plastic baluster to rail connectors and rail to post brackets, non-structural 4X4 plastic lined aluminum post sleeve, a supporting foot piece, an optional cap rail assembly, decorative moldings and post caps.

3.3.1. The top rail and bottom rails are identical and are extruded 6063-T5 or 6063-T6 aluminum components of rectangular cross sectional shape. The upper rail may be also be capped with an optional cap rail assembly. See Figures 1 through 5.

3.3.2. The infill area may be configured in multiple ways using the following aluminum or glass balusters.

- Classic – 6063-T6 Aluminum
- Colonial – 6063-T6 Aluminum
- Estate – 6063-T6 Aluminum
- Traditional – 6063-T6 Aluminum
- Arc – 6063-T52 or 6063-T6 Aluminum
- Baroque – 6061-T6511 or 6063-T6 Aluminum
- Frontier Scenic Glass – Fully Tempered Glass
- Contour Scenic Glass – Fully Tempered Glass
- Scenic Glass – Fully Tempered Glass

See "Baluster Options" section of Figures 1 through 2 and Figures 11 through 19 for dimensional details.

3.3.3. The system is available in various colors and finishes.

4.0 Performance Characteristics

4.1. The guardrail system described in this report has demonstrated the capacity to resist the design loadings specified in Chapter 16 of the IBC and Section R301 of the IRC when tested in accordance with ICC-ES AC273.

5.0 Installation

The guard system shall be installed in accordance with the manufacturer's installation instructions and this report. Where differences occur between this report and the manufacturer's installation instructions, this report shall govern.

5.1. Guards may be assembled in various configurations identified in Figures 1 and 2. Refer to Table 2 for the fastening schedule of all system components.

5.2. Top and bottom rails are attached directly to conventional wood posts, or other suitable wood support structure, with Nylon/Glass Fiber mounting brackets. The wood supports, including wood posts, are outside the scope of this report. See Figures 1, 2, 7 and 8.

5.2.1. Rails may be installed at angles of 22.5 deg and 45 deg to the post face using special angle adapters. See Figures 3, 9, 31 and 32.

5.2.2. Conventional 4X4 wood posts may be covered with the Deckorators extruded aluminum post sleeve which is lined with a .045" plastic coating. See Figure 6

5.2.3. The wood in the supporting structure including support posts shall have a specific gravity of 0.50 or greater (Southern Yellow Pine or better) and a minimum thickness to allow full penetration of the bracket mounting screws

5.3. Balusters are assembled to the rails either by using plastic connectors and brackets shown in figures 20 through 28 and 30, or fastened directly to the face of the rails with screws as indicated in Tables 1 and 2. Figure 1 indicates recognized attachment methods of each baluster type

5.4. A foot piece is installed between the lower rail and the deck surface midway between supports. See Figures 1, 2, 29 and 30.

6.0 Supporting Evidence

6.1. Drawings and installation instructions submitted by the manufacturer.

6.2. Reports of testing and engineering analysis demonstrating compliance with the performance requirements of ICC-ES Acceptance Criteria for Handrails and Guards, AC273, effective March 1, 2008 with additional testing employing increased test loads for compliance with IBC Section 2407 for the systems that utilize glass balusters.

6.3. The reports of testing and engineering analysis demonstrating compliance with the performance requirements of ANSI Z97.1-2014(09), American National Standard for Safety Glazing Materials Used in Buildings, as required by Section 2406 of the IBC and Section R308 of the IRC.

6.4. Documentation of an Intertek approved quality control system for the manufacturing of products recognized in this report.

7.0 Conditions of Use

The guard assemblies identified in this report are deemed to comply with the intent of the provisions of the referenced building codes subject to the following conditions.

7.1. Conventional wood supports including support posts for guards are not within the scope of this report and are subject to evaluation and approval by the building official. Supports must satisfy the design load requirements specified in Chapter 16 of the IBC and must provide suitable material for anchorage of the rail brackets (See 5.2 under "Installation"). Where required by the building official, engineering calculations, and/or accredited third party structural testing, prepared by a licensed design professional shall be provided.

7.2. Only stainless steel fasteners identified in this report are approved for use in preservative or fire-treated wood regulated by the referenced building codes. The compatibility of fasteners and other metallic components, not identified herein, with the supporting structure, including chemically treated wood, is not within the scope of this report.

7.3. Glass used as balusters of guards, regardless of area or height above a walking surface, meets the definition of a hazardous location as defined by Section 2406.4 of the IBC and must be identified by permanent etching as required by Section 2406.3 of the IBC. Each glass baluster must bear the manufacturer's name and/or mark, type of glass (tempered), thickness (5/16"), Size classification (U), drop height class

(A) and the applicable test standard (ANSI Z97.1 -2014(09)).

7.4. Guards utilizing glass balusters are not approved for use in wind-borne debris regions as defined by the IBC in accordance with Section 2407.1.4.

7.5. Maine Ornamental LLC is located in Greene, ME, and operates in accordance with an approved quality control system that includes independent third party inspection by Architectural Testing Inc. (IAS AA-676).

8.0 Identification

The Maine Ornamental LLC., Deckorators® Aluminum Railing assemblies identified in this report, shall be identified with labeling on the individual components or the packaging and include the following;

8.1. Name and/or trademark of the manufacturer

8.2. The identifying mark of the independent inspection agency, (IAS AA-676)

8.3. The ATI Code Compliance Research Report Number (CCRR-0161)

8.4. When applicable, (see Table 1), the following statement: “For Use in One-and Two-Family Dwellings Only.”

9.0 Code Compliance Research Report Use

9.1. Approval of building products and/or materials can only be granted by a building official having legal authority in the specific jurisdiction where approval is sought.

9.2. Code Compliance Research Reports shall not be used in any manner that implies an endorsement of the product by Architectural Testing.

9.3. Reference to the Architectural Testing internet web site address at www.ati-es.com is recommended to ascertain the current version and status of this report.

Table 1
Deckorators® Railing Systems Building Code Recognition

Deckorators® Aluminum Railing Systems ⁽¹⁾	Guardrail Type	Baluster Style		Code Recognition
		Baluster	Connector	
72 in by 42 in 96 in by 42 in	Level ⁽²⁾ & Stair	32 in Classic Aluminum PN 104.3	Classic Baluster Connector PN 107.1,107.2 & 129.1,107.3 Stair	IBC - All Use Groups & IRC One- and Two-Family Dwellings
		32 in Frontier Scenic Glass PN 116.1	Nylon Baluster Connectors PN 125.1 & 126.1	
		32 in Contour Scenic Glass PN 124.1	Nylon Baluster Connectors PN 127.1 & 128.1	
		32 in, Estate Aluminum PN 114.3	Estate Baluster Connectors PN 108.1 & 130.1	
		40 in Baroque Aluminum PN 110.3	Face Mounted to Rails	
72 in by 46 in 96 in by 46 in	Level ⁽²⁾ & Stair	36in - Classic Aluminum PN 104.4	Classic Baluster Connector PN 107.1,107.2 & 129.1,107.3 Stair	
72 in by 36 in 96 in by 36 in	Level ⁽²⁾ & Stair	26 in Scenic Glass PN 123.1	Nylon Baluster Connectors PN 125.1 & PN 126.1 Stair	IRC (only) One- and Two-Family Dwellings ⁽³⁾
		32 in Contour Scenic Glass PN 124.1	Face Mounted to Rails	
		32 in Frontier Scenic glass PN 116.1		
		32 in Traditional Aluminum PN 111.2		
		32.25 in Arc Aluminum PN 112.2		
		32.25 in Baroque Aluminum PN 110.2		
		26 in Colonial Aluminum PN 113.1	Classic Baluster Connector PN 107.2 or 107.1 & 107.3 or 129.1 Stair	
		26 in – Classic Aluminum PN 104.2		
		26" Estate Aluminum - PN 114.2	Estate Baluster Connector PN 108. & PN 130.1 Stair	

¹ Guardrails are qualified up to and including the listed maximum guardrail system dimensions for use in the referenced Code Occupancy Classification.

² All level systems included in Table 1 may use the 22.5° and 45° angle adapter under both IRC and IBC recognition.

³ The use of this product shall be limited to exterior or interior use as a guard system for balconies and porches for one- and two-family dwellings of Type V-B (IBC) construction and dwellings constructed in accordance with the IRC.

Table 2
Deckorators® Railing System Fastening Schedule (Level / Stair)

<u>Connection</u>	<u>Fastener</u> ³
Level Rail Bracket to Post ¹	Two #8 x 2" long screws
Level Rail Bracket to Rail ²	Three #8 x 1" long screws
Stair Rail Bracket to Post ¹	Two #8 x 2" long screws
Stair Rail Bracket to Rail ²	Four #8 x 1" long screws
22.5 and 45 deg Angle Rail Bracket Adaptor to Post ¹	Two #8 x 2 ½" long screws
Stair Rail Bracket to 45 deg Angle Rail Bracket Adaptor	Two #10 x 0.70" long screws ⁴ with two 0.374 in diameter by 0.492 in long brass inserts and 0.369 in diameter by 0.031 in thick brass external retaining rings
Support Block Connector	One #8 x 1.5" long screw
<u>In-Fill</u>	<u>Fastener</u> ³
Classic & Colonial Aluminum Baluster connector to rail ¹	One (per connector) #8 x 1.5" long screw
Glass Baluster Connector to Rail ¹ (Scenic, Frontier, and Contour)	Two (per connector) #8 x 1.5" long screws
Glass Baluster Stair Connector to Rail (Scenic, Frontier, and Contour)	One (per baluster end) #8 x 1.5" long screws and one (per end) #8 x 4" long screw
Frontier Glass Baluster Directly to Face of Rail ¹	Two (per baluster end) #8 x 1.5" long screws installed through pvc grommet supplied with glass.
Contour Glass Baluster Directly to Face of Rail ¹	Two (per baluster end) #8 x 1.5" long screws installed through pvc grommet supplied with glass.
Traditional Baluster directly to Face of Rail	Two (per baluster end) #10x 1.5" long with ½" non-threaded shank screws
Baroque Aluminum Baluster Directly to face of rail	Two (per baluster end) #8 x 1.5" long screws
Arc Aluminum Baluster Directly to Face of Rail	Two (per baluster end) #8 x 1.5" long screws
Estate Aluminum Baluster	Two Plastic Estate Baluster Connectors (PN 108.1) with #8 x 1.5" long screws

¹ Holes must be pre-drilled with 1/8" dia drill

² Holes must be pre-drilled with 9/64" dia drill

³ All Screws are stainless steel Flathead screws with square head drive, unless noted otherwise.

⁴ Stainless steel phillips flathead screws

ITEM NO.	PART NUMBER 36"/42" Assy	Description	QTY.
1	109.1	Horizontal Bracket	4
2	101.4	"2x4" Aluminum .08" thick	2
3	104.2/104.3	Classic Baluster	15
4	107.2	Baluster Connector	30
5	107.1	Designer Baluster Connector	2
6	105.2	Classic Baluster Foot Piece	1
7	115.2/115.4	4"x4" Aluminum Post Sleeve	2

Baluster Options 36" System		
Baluster Name	Part No.	Connector Part No.
Baroque	110.2	1) Mech.
Traditional	111.2	1) Mech.
Classic	104.2	107.1 or 107.2
Arc	112.2	1) Mech.
Colonial	113.1	107.1 or 107.2
Estate	114.2	108.1
Frontier Glass	116.1	1) Mech.
Contour Glass	124.1	1) Mech.
Scenic Glass	123.1	125.1

Baluster Options 42" System		
Baluster Name	Part No.	Connector Part No.
Baroque	110.3	1) Mech.
Classic	104.3	107.1 or 107.2
Estate	114.3	108.1
Frontier Glass	116.1	125.1
Contour Glass	124.1	127.1

1) Balusters are fastened directly to the exterior face of each rail using screws as indicated in Table 2. No plastic connectors are needed.

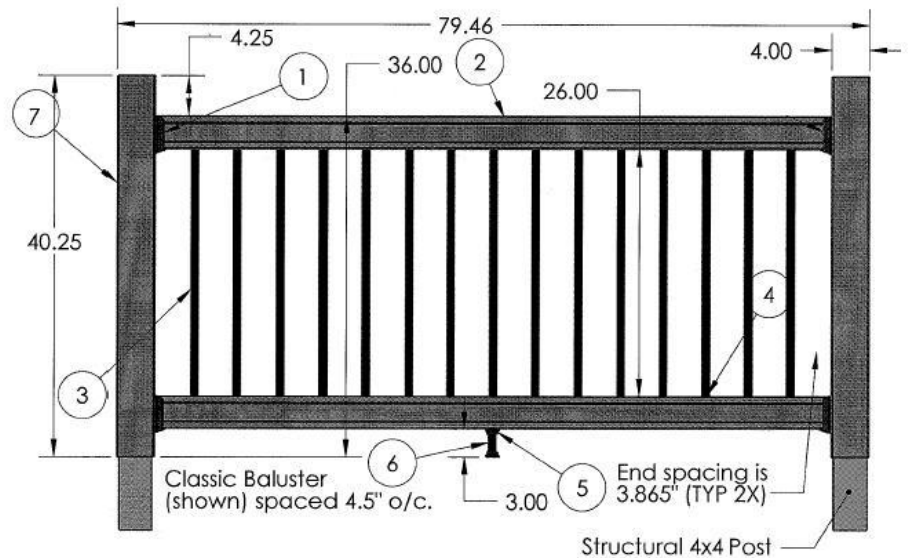

36" Deckorators Railing System

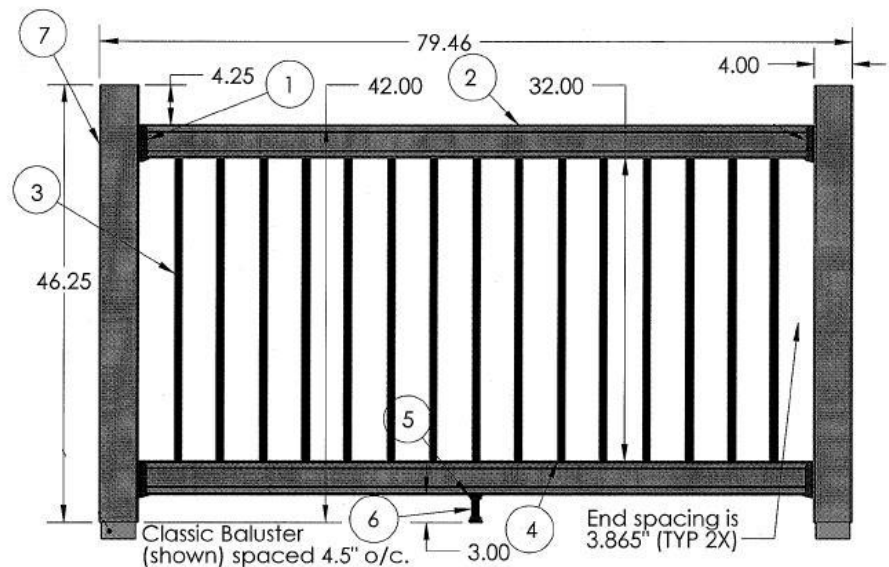

42" Deckorators Railing System

**Figure 1
Deckorators 72-inch Long Railing System Assembly**

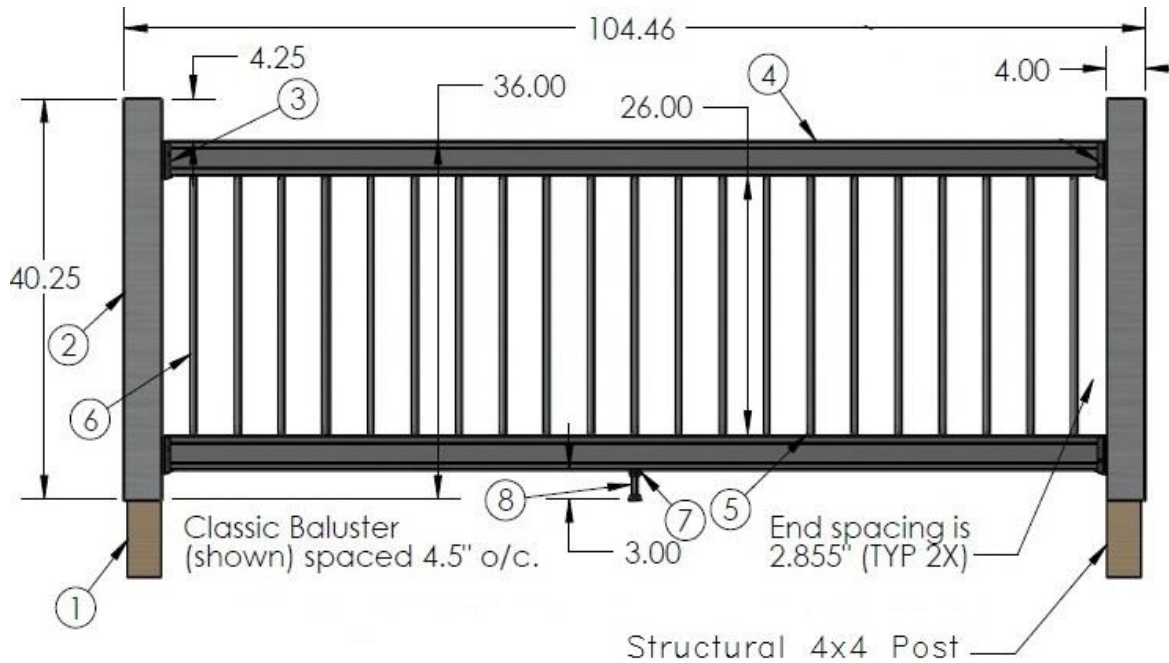

ITEM NO.	PART NUMBER	DESCRIPTION	QTY.
1	4x4	Structural 4x4 Wood Post	2
2	115.2	4"x4" Aluminum Post Sleeve	2
3	109.1	Horizontal Bracket	4
4	101.5	"2X4" Aluminum Hand Rail - .118" thick	2
5	107.2	Connector for Classic Baluster	42
6	104.2	Deckorator 26 Classic Baluster	21
7	107.1	Connector for Classic Baluster	2
8	105.2	Classic Baluster Foot Piece	1

Baluster Options		
Baluster Name	Part No.	Connector Part No.
Baroque	110.2	Face Mtd.
Traditional	111.2	Face Mtd.
Classic	104.2	107.1 or 107.2
Arc	112.2	Face Mtd.
Colonial	113.1	107.1 or 107.2
Estate	114.2	108.1
Glass	116.1	Face mtd. with 132.1
Glass	124.1	Face mtd. with 132.1
Glass	123.1	125.1

36" Deckorators Railing System

**Figure 1 (Continued)
Deckorators 96-inch Long Railing System Assembly**

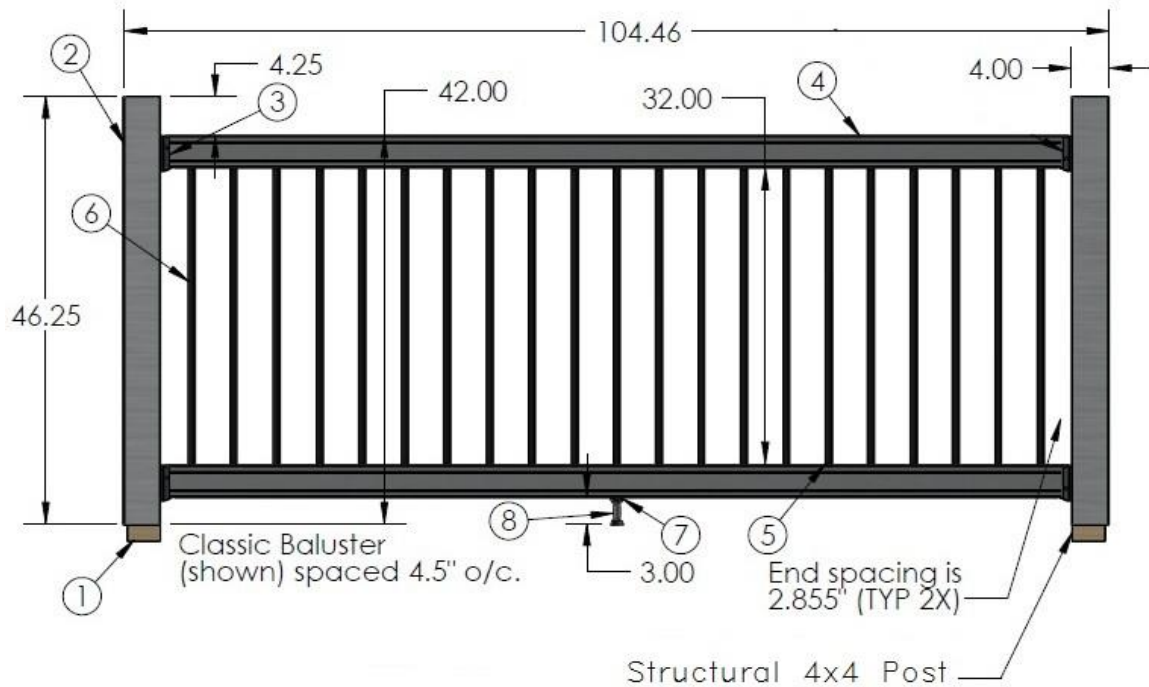

ITEM NO.	PART NUMBER	DESCRIPTION	QTY.
1	4x4	Structural 4x4 Wood Post	2
2	115.4	4"x4" Aluminum Post Sleeve	2
3	109.1	Horizontal Bracket	4
4	101.5	"2X4" Aluminum Hand Rail - .118" thick	2
5	107.2	Connector for Classic Baluster	42
6	104.3	Deckorator 32" Classic Baluster	21
7	107.1	Connector for Classic Baluster	2
8	105.2	Classic Baluster Foot Piece	1

Baluster Options		
Baluster Name	Part No.	Connector Part No.
Baroque	110.3	Face Mtd.
Classic	104.3	107.1 or 107.2
Estate	114.3	108.1
Glass	116.1	125.1
Glass	124.1	127.1

42" Deckorators Railing System

Figure 1 (Continued)
Deckorators 96-inch Long Railing System Assembly

ITEM NO.	DESCRIPTION
1	Structural 4x4 Wood Post
2	4"x4" Aluminum Post Sleeve
3	"2x4" Aluminum Rail - .08" thick
4	Stair Bracket
5	Stair Connector
6	Colonial Baluster
7	Classic Baluster Foot Piece
8	Connector for Classic Baluster
9	Designer Stair Adaptor
10	Glass Stair Adaptor
11	Glass Baluster Connector
12	Glass Baluster

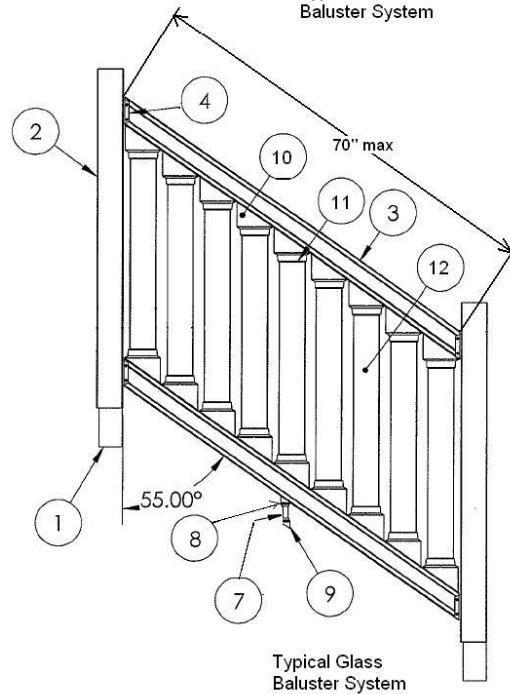
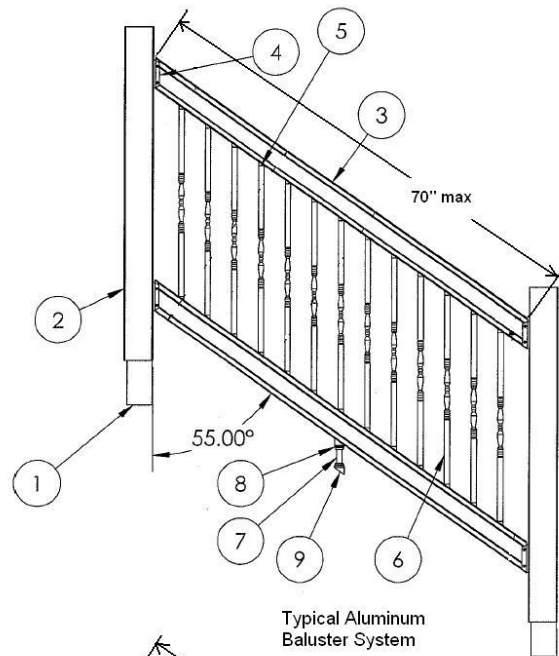
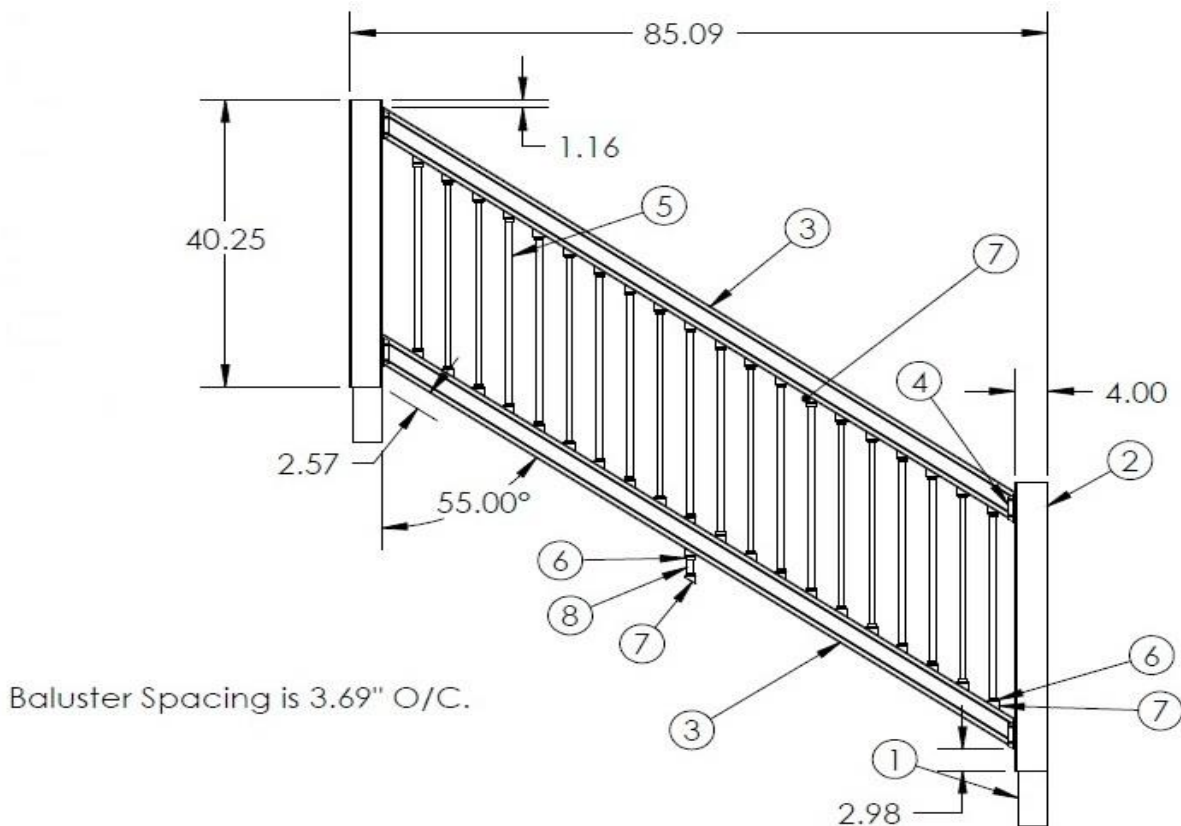
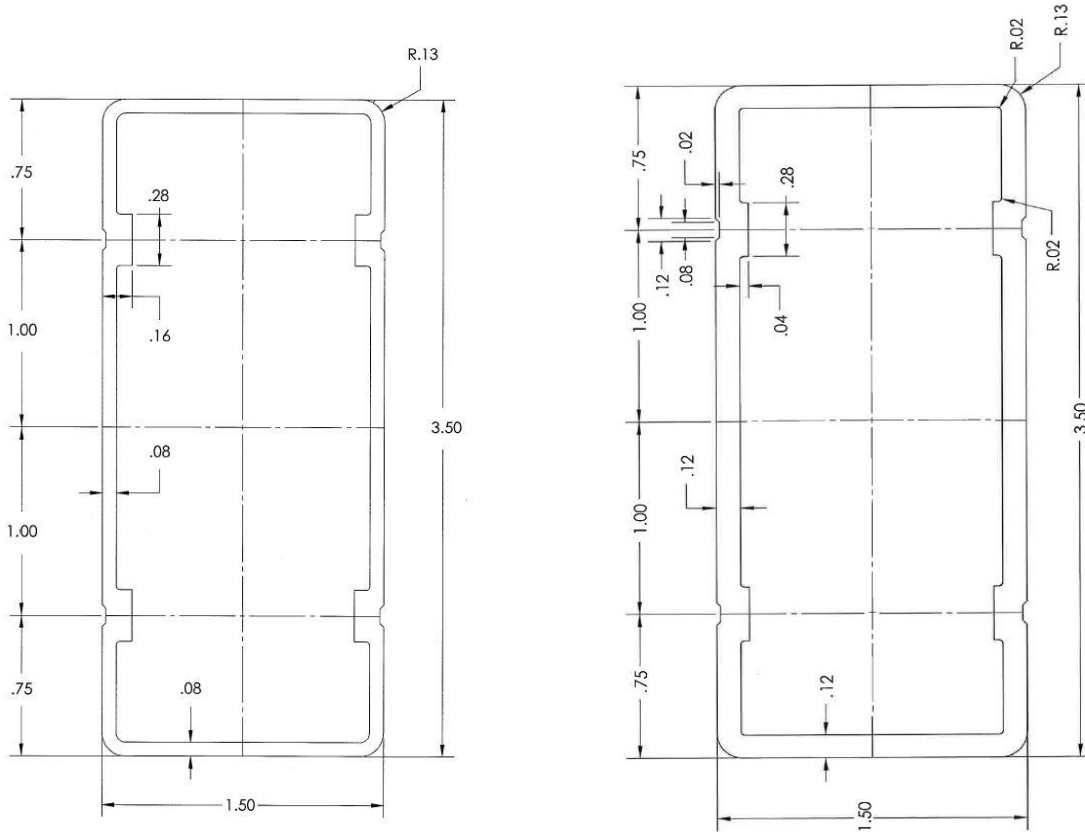

Figure 2
Deckorators 72-inch Long Railing System Stair Assembly



ITEM NO.	PART NUMBER	DESCRIPTION	QTY.
1	4x4	Structural 4x4 Wood Post	2
2	115.2	4"x4" Aluminum Post Sleeve	2
3	101.5	"2X4" Aluminum Hand Rail - .118" thick	2
4	118.1	Stair Bracket	4
5	104.2	Deckorator 26" Classic Baluster	20
6	107.1	Connector for Classic Baluster	42
7	129.1	Designer Stair Adaptor	42
8	105.2	Classic Baluster Foot Piece	1

Figure 2 (Continued)
Deckorators 96-inch Long Railing System Stair Assembly

72''-Long Rail PN 101.4 (Upper/Lower)
96''-Long Rail PN 101.5 (Upper/Lower)
**Figure 3
Rail Sections**

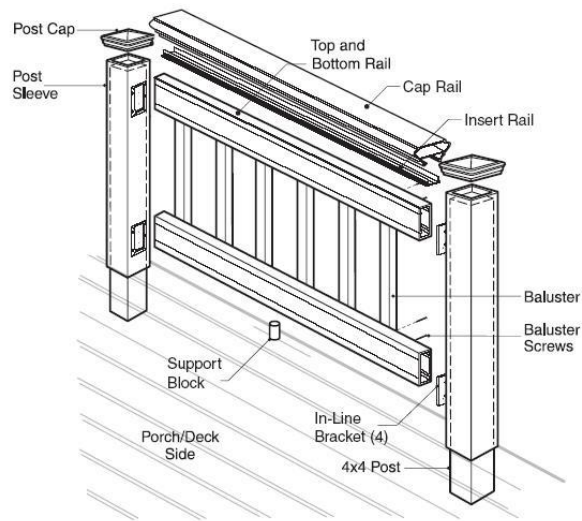

Figure 4
General Assembly with Optional Cap Rail

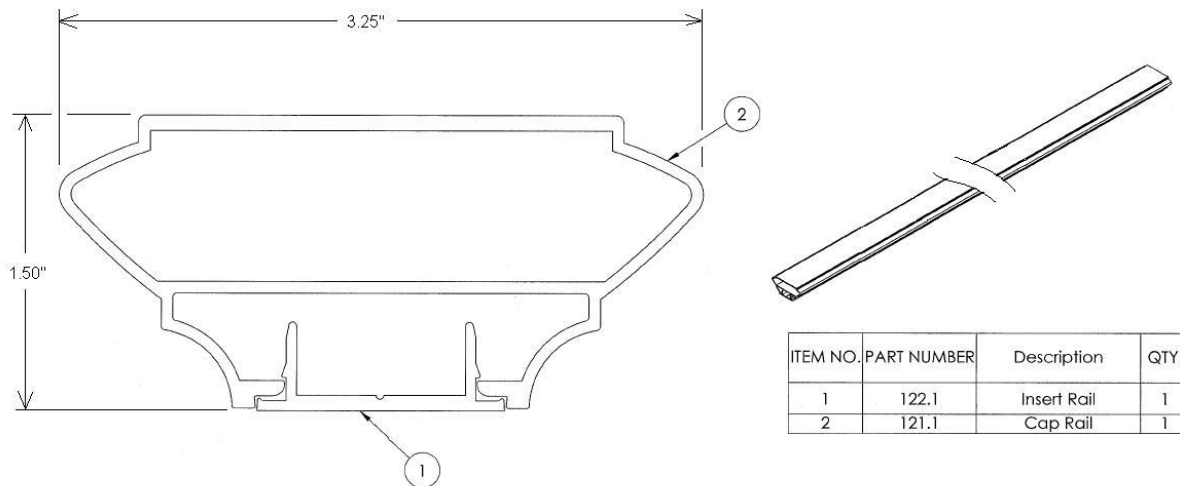

Figure 5
Optional Cap Rail Assembly

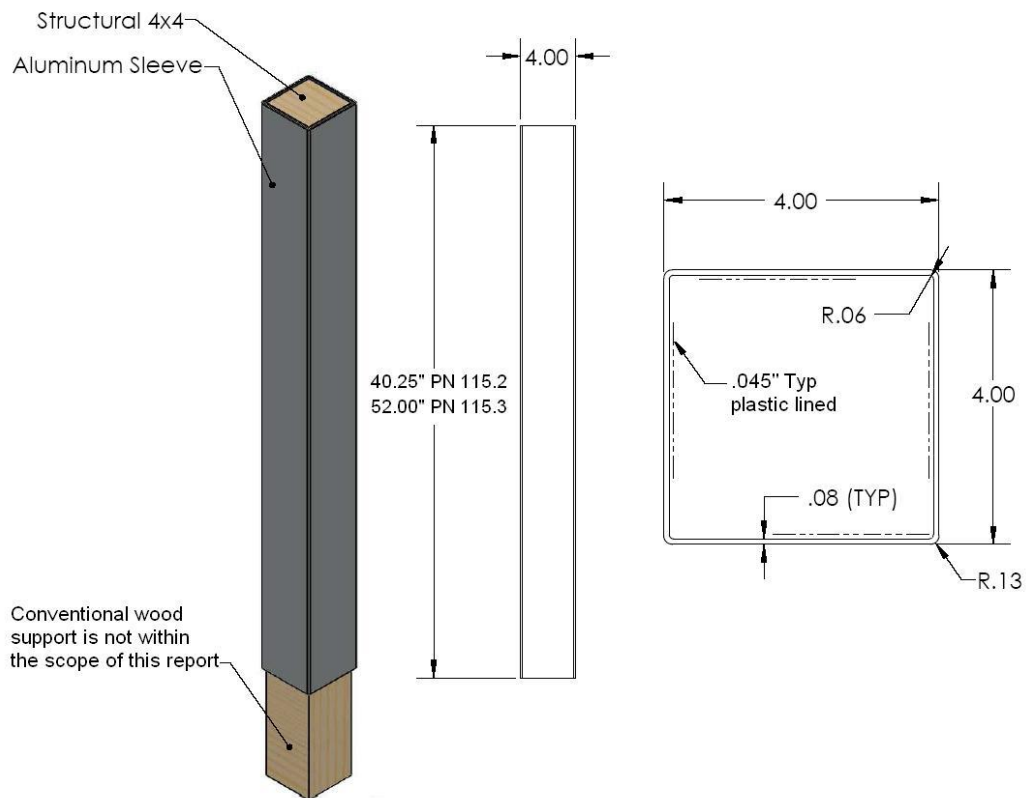

Figure 6
4X4 Post Sleeve PNs 115.2/115.3/115.4

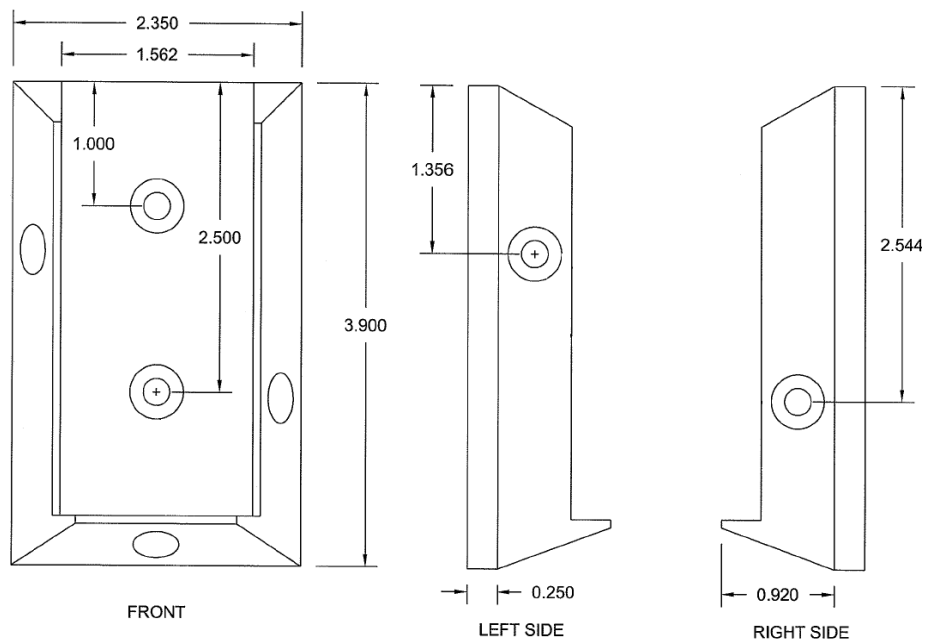

Figure 7
Nylon Glass Fiber Drop In Bracket - Level, PN 109.1

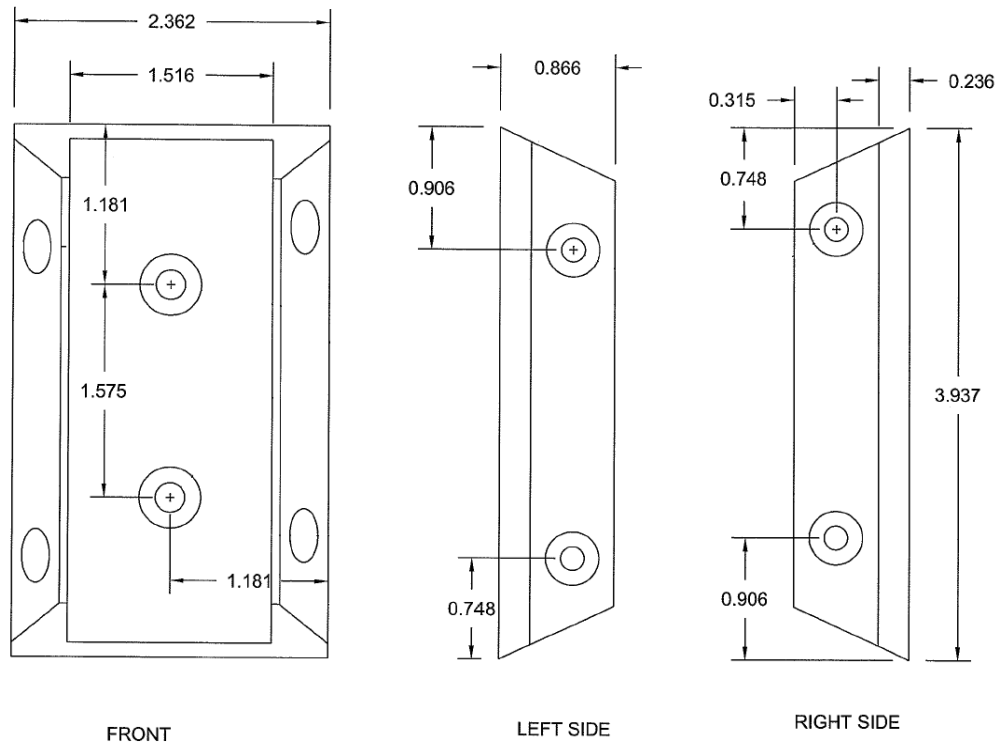

Figure 8
Nylon Glass Fiber Drop In Bracket – Stair, PN 118.1

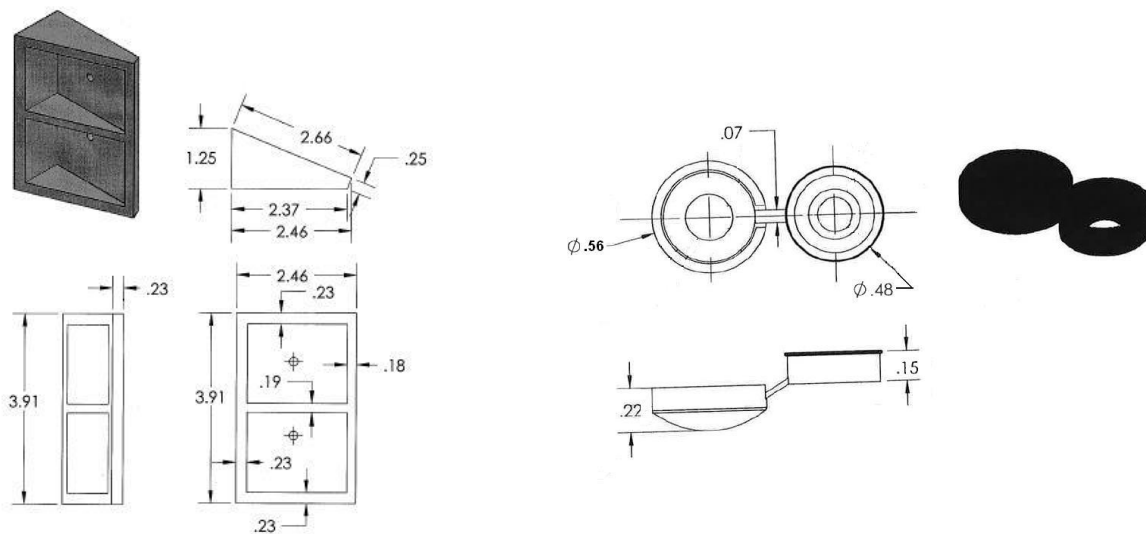

Figure 9
22.5 Degree Angle Wedge Kit PN 119.1
 (Used with Stair Rail Bracket PN 118.1)

Figure 10
Hinge Snap Cap PN 132.1
 (for face mounting of glass balusters
 PNs 116.1/124.1)

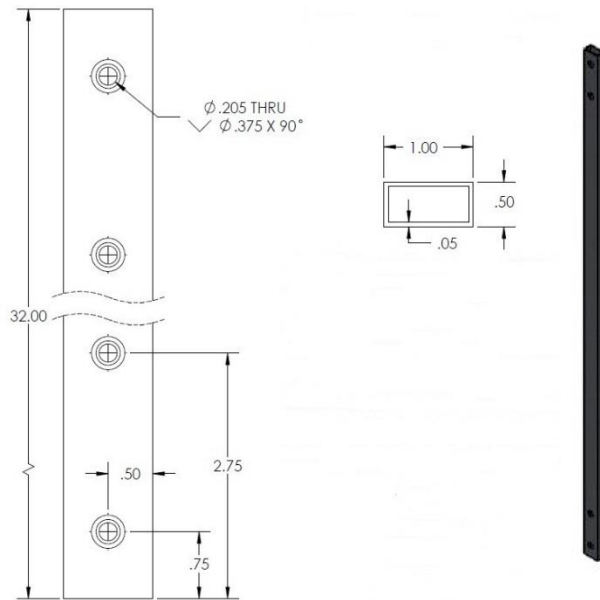

Figure 11
Traditional Baluster PN 111.2

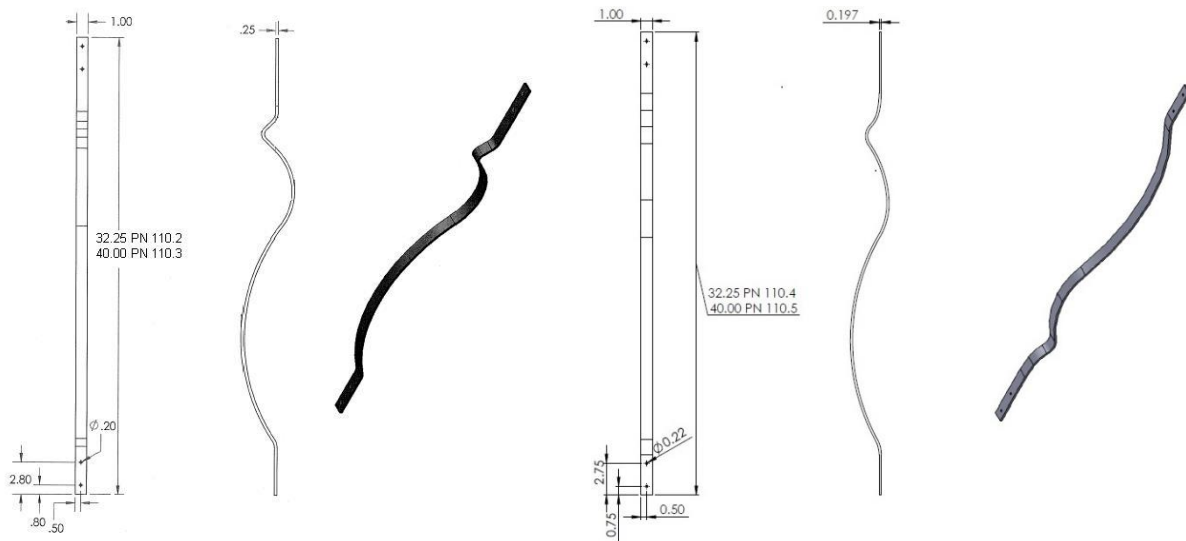

Figure 12
Baroque Baluster PNs 110.2/110.3/110.4/110.5

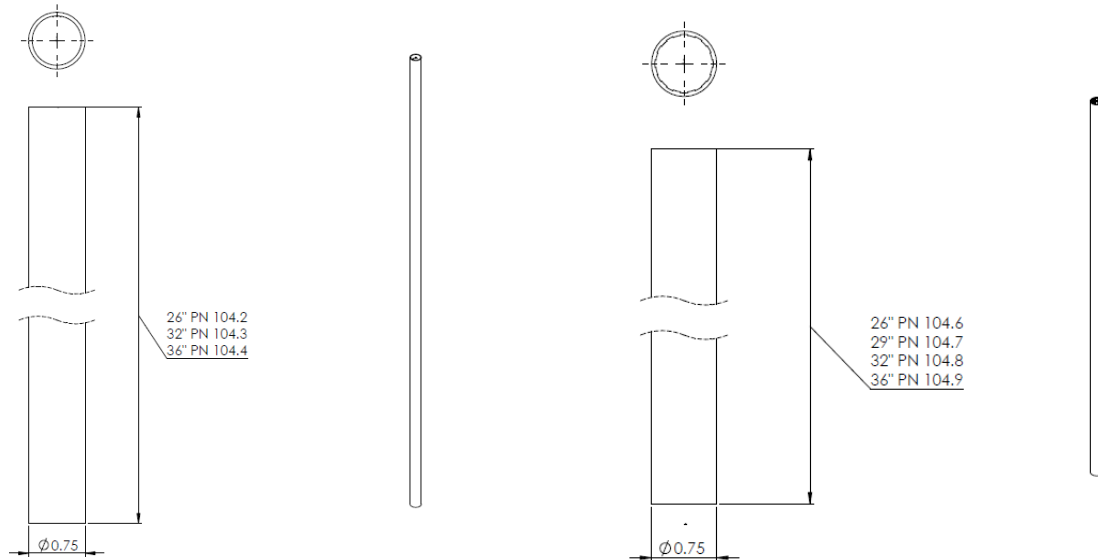

Figure 13
Classic Baluster and Splined Classic Baluster
PNs 104.2/104.3/104.4/104.6/104.7/104.8/104.9

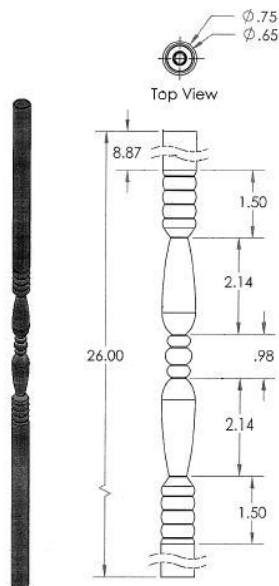

Figure 14
Colonial Baluster PN 113.1

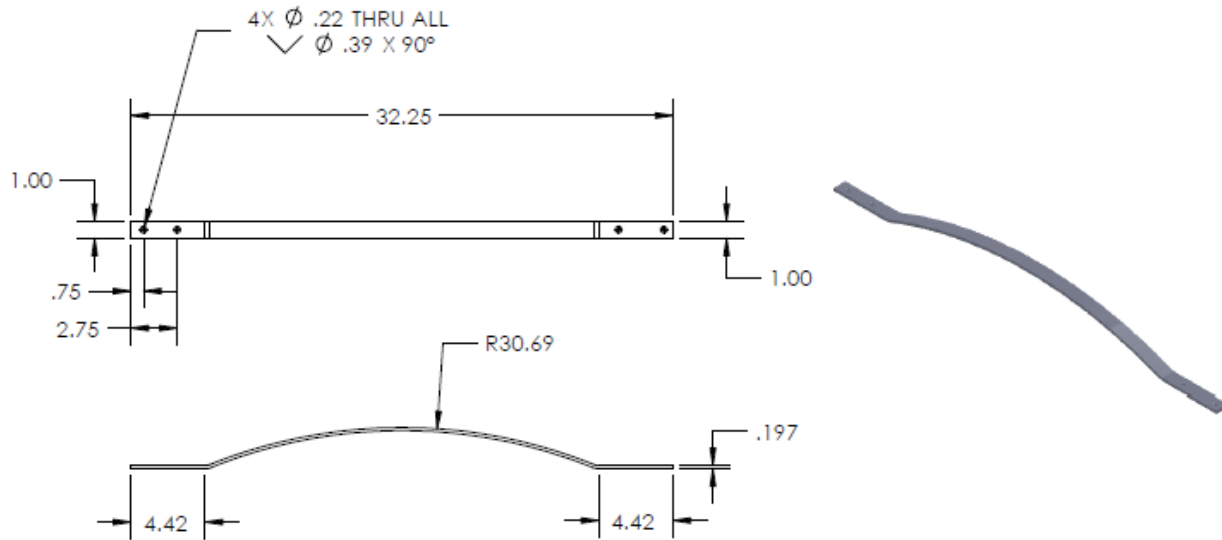

Figure 15
Arc Baluster PN 112.2

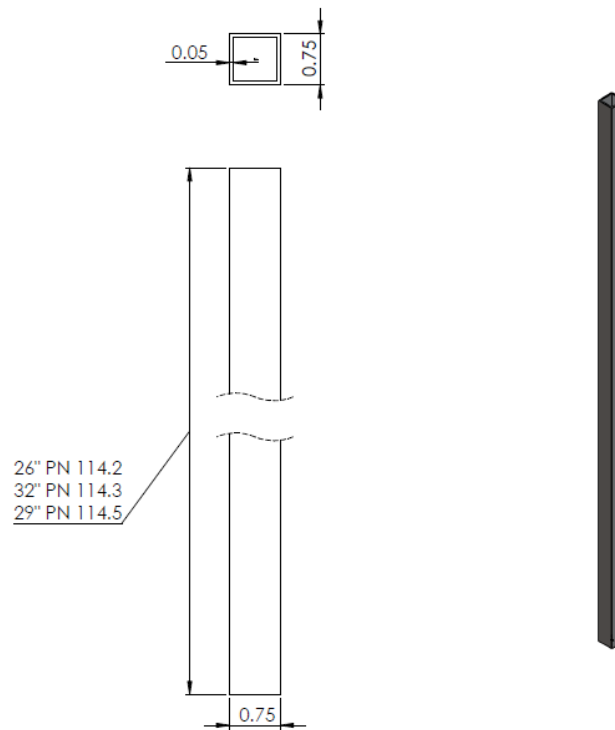

Figure 16
Estate Baluster

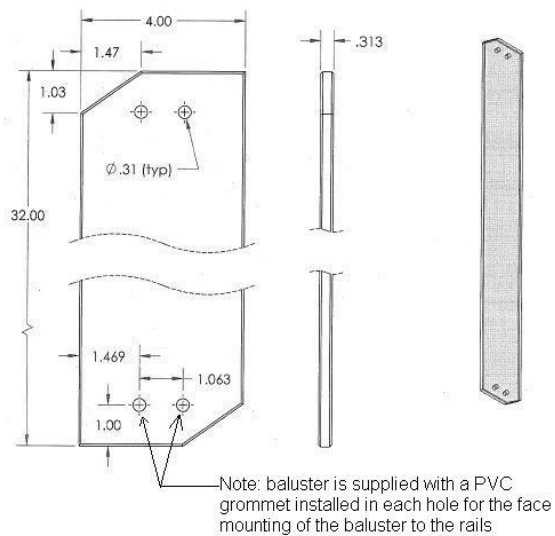

Figure 17
Frontier Scenic Glass Baluster PN 116.1

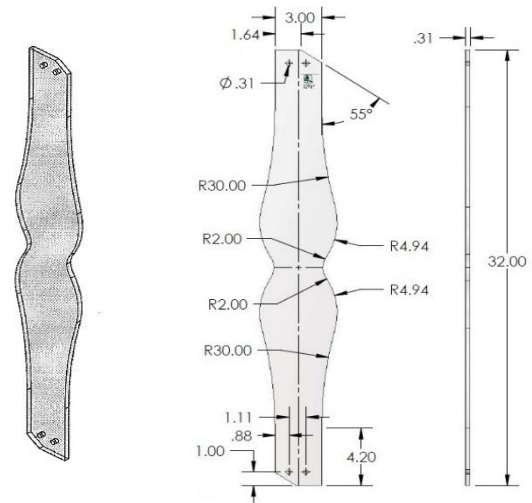

Figure 18
Contour Scenic Glass Baluster PN 124.1

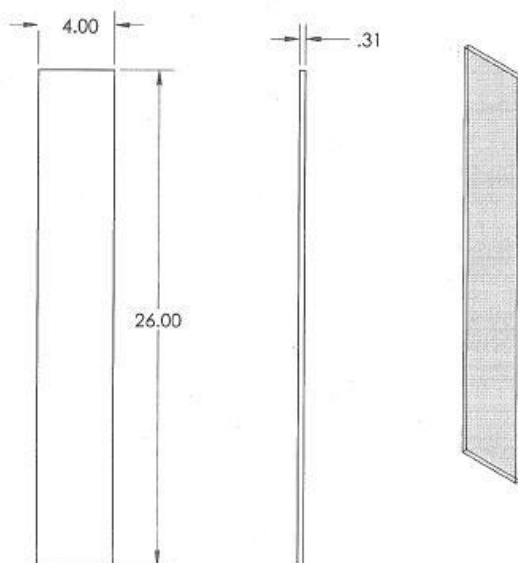

Figure 19
26" Scenic Glass Baluster PN 123.1

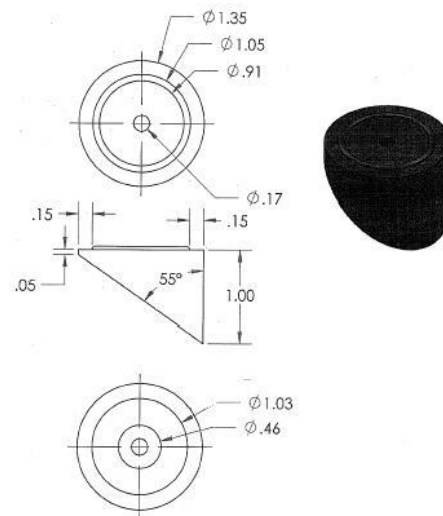

Figure 20
Designer Stair Adapter PN 129.1 (Used with Designer Baluster Connector PN 107.1 and Classic Balusters 104.2, 104.3, 104.4 and Colonial Baluster 113.1)

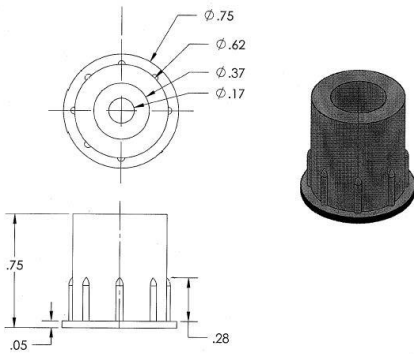

Figure 21
Classic Baluster Connector PN 107.2
 (for Classic Baluster PN 104.2, 104.3,104.4)
 and Colonial Baluster PN 113.01)

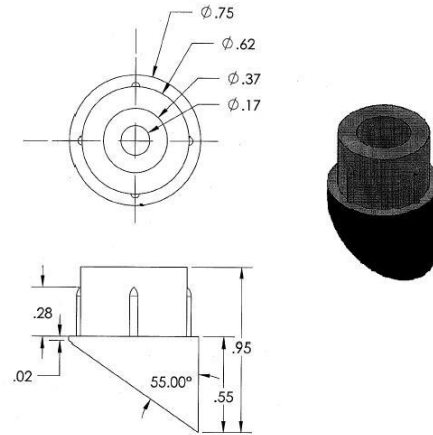

Figure 22
Classic Baluster Stair Connector PN 107.3
 (for Classic Baluster PNs 104.2, 104.3,104.4)
 and Colonial Baluster PN 113.01)

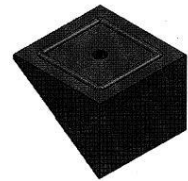
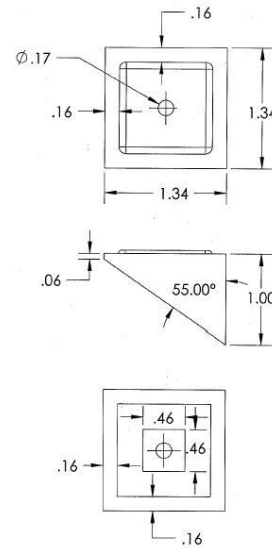
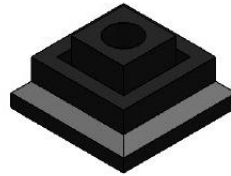
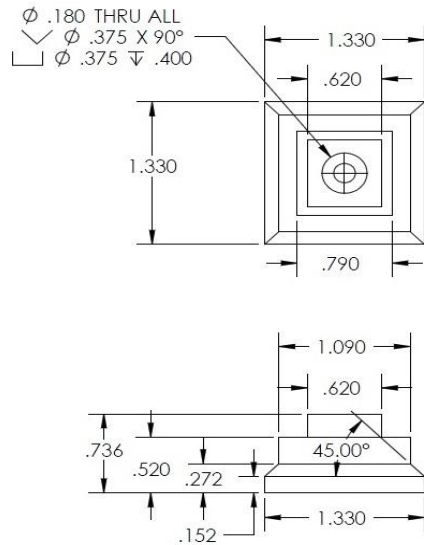

Figure 23
Estate Baluster Connector PN 108.1
 (for Estate Baluster PNs 114.2, 114.3)

Figure 24
Estate Baluster Stair Adaptor PN 130.1
 (for Estate Baluster PNs 114.2, 114.3)

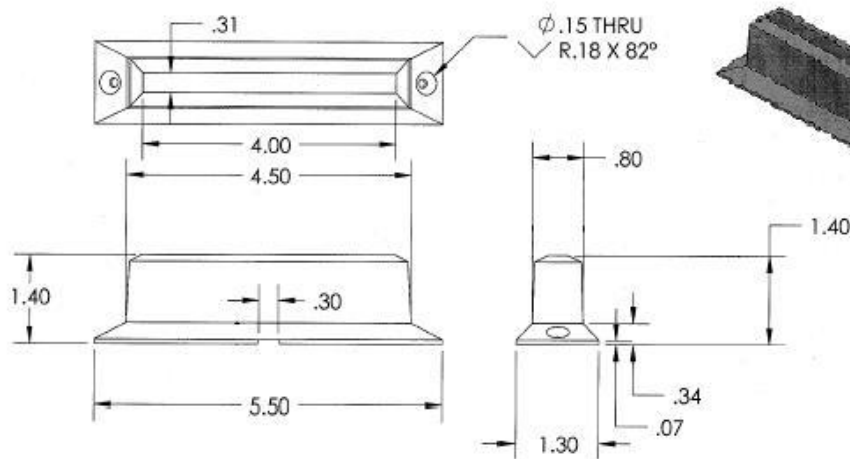

Figure 25
Frontier Glass Baluster Connector PN 125.1
 (used with Frontier Baluster PN 116.1 and Scenic Baluster PN 123.1)

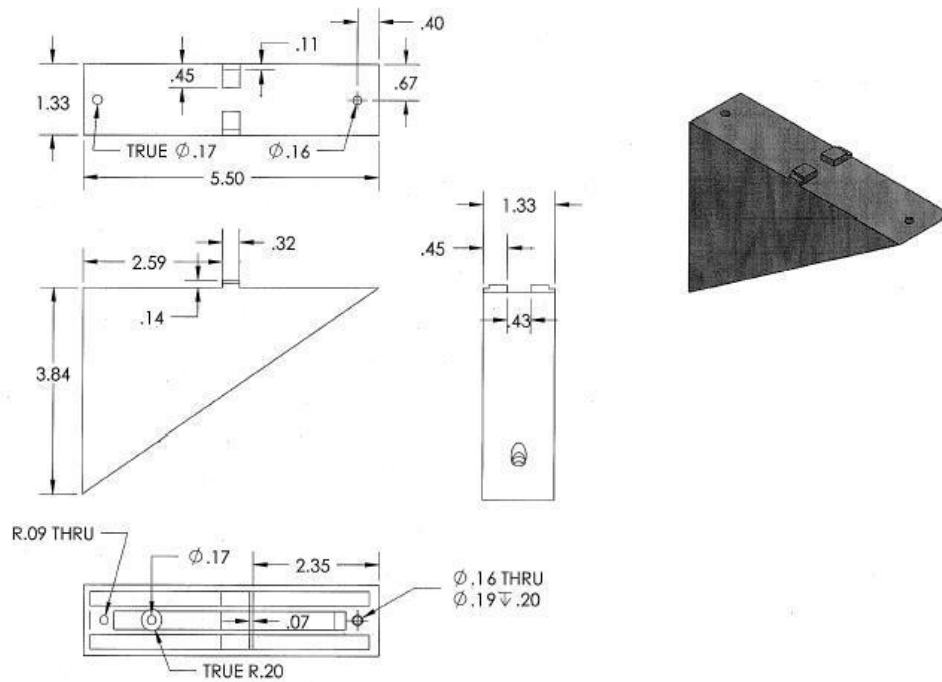

Figure 26
Frontier Scenic Glass Baluster Stair Adapter PN 126.1
 (used with Frontier Baluster PN 116.1, Scenic Baluster PN 123.1 and Connector PN 125.1)

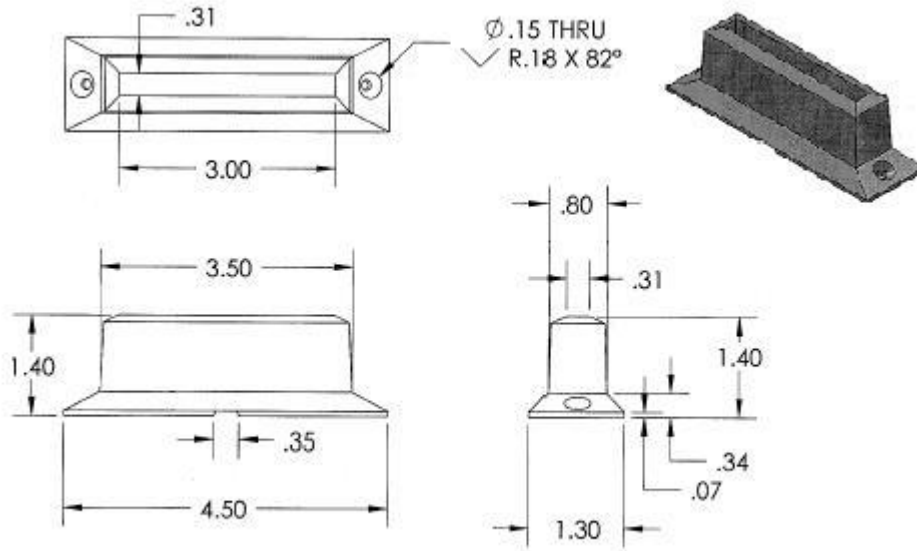

Figure 27
Contour Glass Baluster Connector PN 127.1
 (used with Contour Baluster PN 124.1)

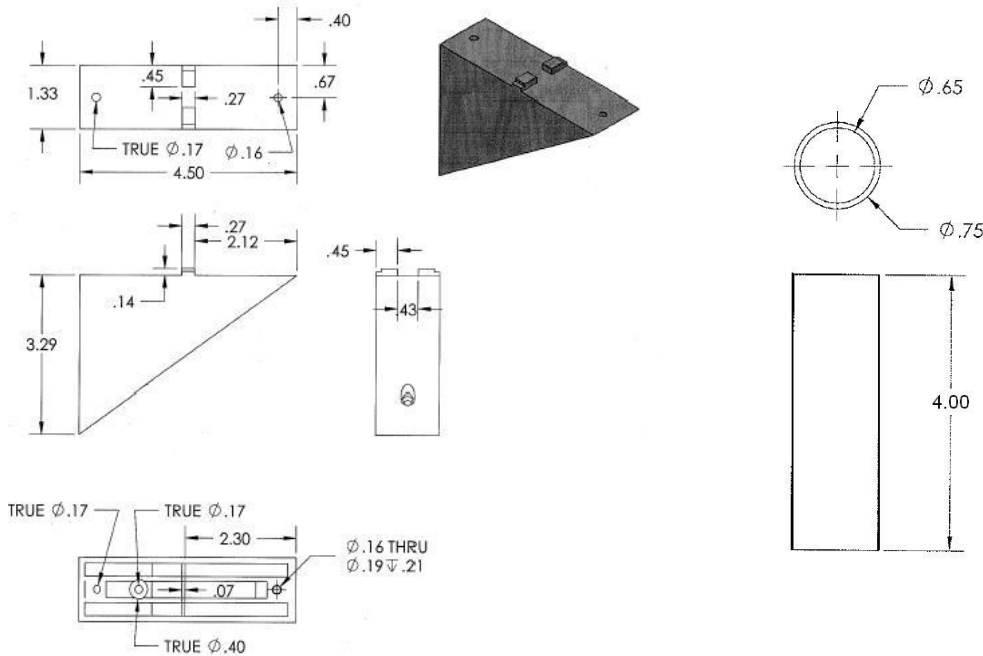

Figure 28
Contour Scenic Glass Baluster Stair Adapter PN 128.1
 (used with Contour Baluster PN 124.1 and Connector PN 127.1)

Figure 29
Foot Piece PN 105.2

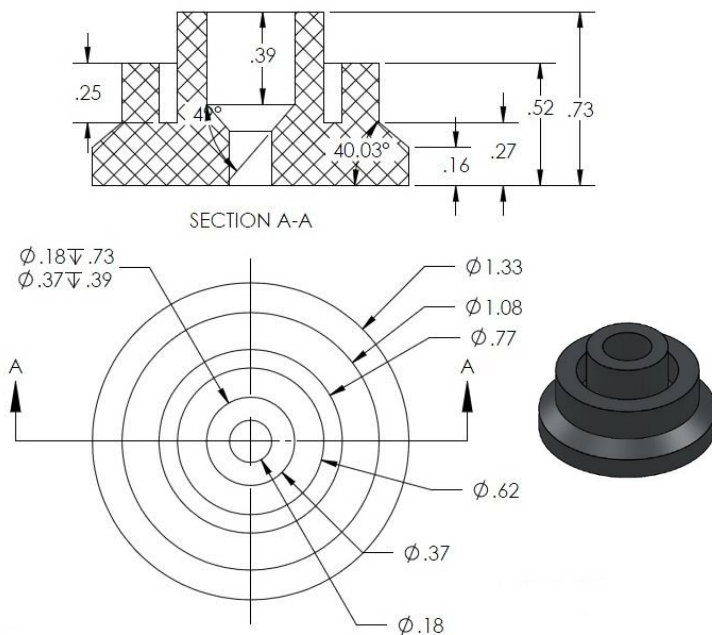

Figure 30
Support Block Connector and Designer
Baluster Connector PN 107.1 (used with
 Foot Piece PN 105.2)

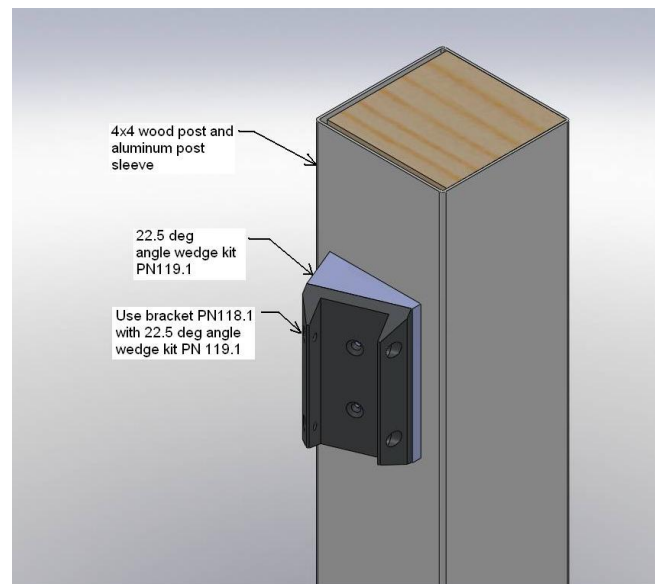

Figure 31
Deckorators® Railing System
22.5° Angled Rail Assembly

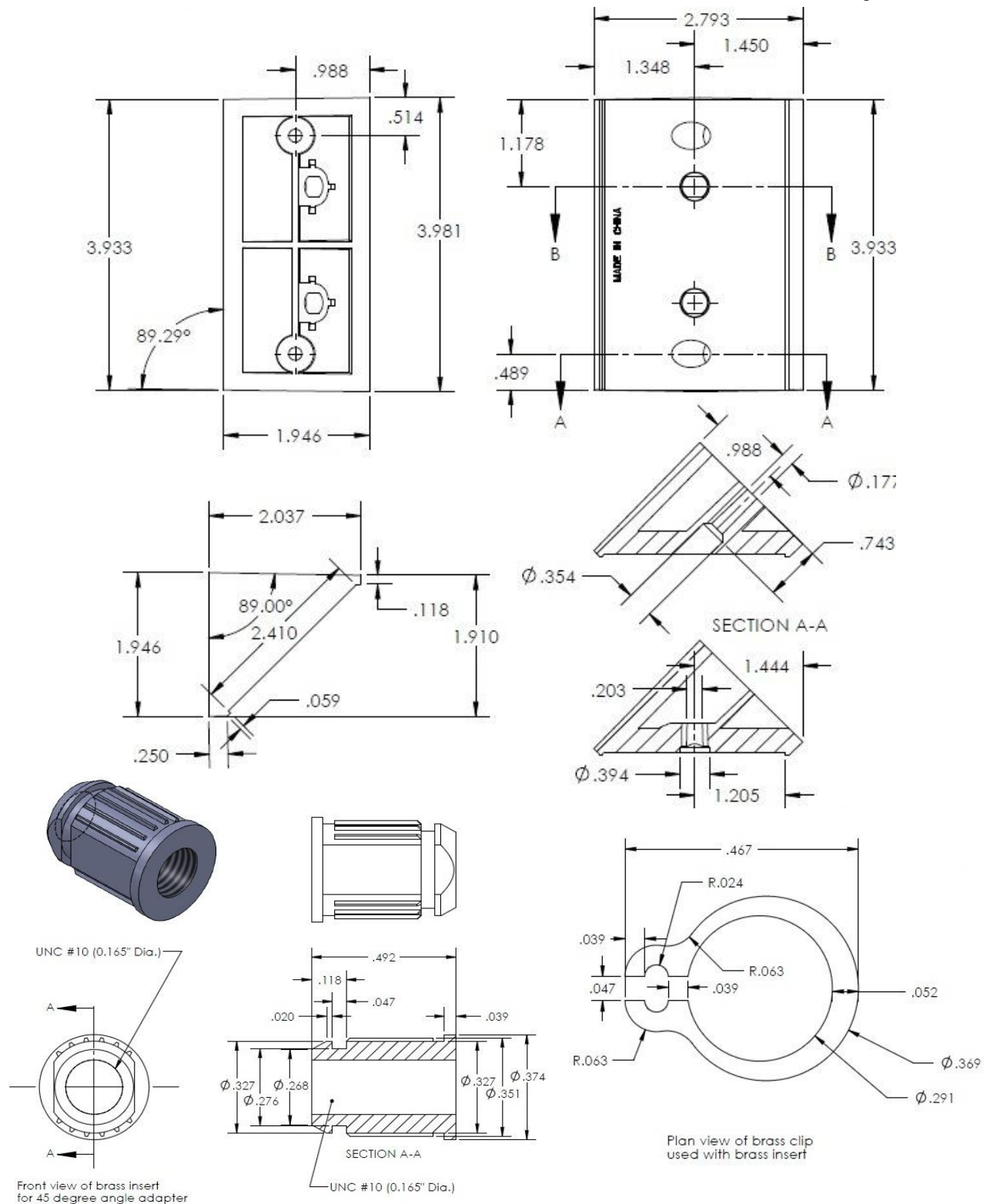

Figure 32
45° Angled Rail Bracket Adaptor PNs 145.1/146.1/147.1