

## Code Compliance Research Report

CCRR-0173

Subject to Renewal: 04/22/2018  
Visit [www.archtest.com](http://www.archtest.com) for current status

Issued: 05/01/2017  
Revised: 09/21/2017  
Page 1 of 12

**Kalwall Corporation**  
1111 Candia Rd  
Manchester, NH 03109  
(603) 627-3861  
[www.kalwall.com](http://www.kalwall.com)

### 1. Subject

*Kalwall* Translucent Sandwich Panels

### 2. Research Scope

#### 2.1 Building Codes:

2012 International Building Code (IBC)

2015 International Building Code (IBC)

#### 2.2 Properties:

Physical Properties

Structural Performance

Surface Burning

Fire Classification

Durability

Water Resistance

Air Infiltration

### 3. Description

3.1 *General* – *Kalwall* Translucent Sandwich Panels are light-transmitting roof and wall panels and/or plastic glazing as defined in IBC Section 2602, and conforming with IBC Section 2606, Light Transmitting Plastics.

3.1.1 Panels are used as exterior or interior non load-bearing walls, wall glazing, roof panels and skylight glazing. When assembled, panels comprise a water resistant exterior envelope. Typical uses include curtain walls, roof coverings, skylights, pedestrian walkway covers and interior partitions.

3.2 *Components & Materials* – *Kalwall* Translucent Sandwich Panels consist of fiberglass-reinforced plastic (FRP) translucent face sheets that are permanently bonded with an adhesive to a grid-frame core, constructed of interlocked, structural aluminum I-beams. Panels are 2-3/4" and 4" nominal thickness with 4' widths, and lengths up to 20'. See Figures 2 thru 4.

3.2.1 FRP facings are produced in various types for interior and exterior face panels. See Table 1 for face sheet types, thicknesses and plastic classifications.

3.2.2 Grid members include an extruded aluminum (6005-T5) I-beam and various size thermally broken I-beams which consist of extruded aluminum (6005-T5) flanges and an FRP web. I-beams are configured in several different grids with I-beams spaced from 8" to 24" on center, see Table 3.

3.2.2.1 Thermally Broken I-beams are produced in various sizes: 2-5/8" Light I-beam, 2-5/8" Heavy I-beam and 3-7/8" Heavy I-beam. The web is 0.07" thick fiberglass reinforced plastic which is permanently attached to extruded aluminum flanges by crimping and adhesion. See Figure 1.

3.2.2.2 Additional extruded aluminum (6063-T5 or 6063-T6) framing members utilized for field assembly and installation include heads, sills, and battens and may include a 3-1/4" integral stiffener. See Figures 2 thru 4.

3.3 Panels are fabricated in two different orientations of grid-core framing.

3.3.1 Longitudinal grid-core framing utilizes continuous I-beams spanning the panel length (See Figure 2).

3.3.2 Transverse grid-core framing utilizes continuous I-beam framing spanning the width of the panel. Transverse grid-core panels are supported throughout the panel length with either a continuous 3-1/4" aluminum integral stiffener (See Figure 3) or external supports/ structural framing. See Figure for 4 for general detail of coping integral stiffener.

### 4. Installation

Installation shall be in accordance with the applicable code, manufacturer's installation instructions and this report. Where differences occur between this report and the manufacturer's installation instructions, this report shall govern.

4.1 *Kalwall* Translucent Sandwich Panels' standard installation is the Clamp-tite™ Installation System. Clamp-tite™ uses two-piece

aluminum extrusions with stainless steel screws and sealing tape for installation. An optional thermal brake incorporating an Insulbar® nylon bridge between aluminum extrusions may be used in applications limited to resisting wind load.

4.2 *Sealants* – An elastic type sealant, i.e. *Kalseal*, seals butting joints and all head, sill and jamb fasteners. A non-hardening type bed caulk, i.e. *Kalcaulk*, seals between the opening and the interior head, sill, and jamb members.

## 5. Performance

5.1 *Kalwall* Translucent Sandwich Panels are designed to support transverse loads applied normal to the panel face in flexure between continuous structural supports located at each end of the continuous grid-core framing members. Allowable spans and loads are based upon the design capacities of the grid-core framing members (See Table 2) and the integral stiffener (ISH) member for panels fabricated with transverse grid-core framing.

5.1.1 Maximum allowable spans and transverse loads for the panels installed in accordance with this report are indicated in Tables 4 thru 12. Allowable spans and loads are determined by the lesser of the limiting conditions which include deflection, flexural strength, shear strength and web crippling. Maximum allowable spans in roof live load tables found in this report include consideration for a 300 lb. concentrated live load per Section 1607.4 and Table 1607.1 of the IBC. Maximum allowable roof spans must consider required roof live load and wind load and, shall be governed by the lesser allowable span.

5.2 Fire – Plastic combustibility classification, surface burning (finish) classification and roofing fire classification are presented in Table 1.

5.2.1 All FRP sheet materials recognized in this report comply with IBC Section 2606.4, Specification for light-transmitting plastics. FRP facing materials have combustibility classification CC1 or CC2 determined in accordance with ASTM D 635 (See Table 1).

5.2.2 FRP facing materials are a Class A, B or C finish material based upon flame spread and smoke development index determined in accordance with UL 723 for classification in accordance with IBC Section 803 (See Table 1).

5.2.3 Specific roof panel assemblies are Class A or Class B roof covering systems determined in accordance with UL 790 for Fire classification in

accordance with IBC Section 1505. See Table 1 for exterior facing types used with classified panels.

5.3 Air Infiltration – The *Kalwall* Translucent Sandwich Panels have an air leakage less than 0.3 cfm/ft<sup>2</sup> when tested in accordance with ASTM E283.

## 6. Supporting Evidence

6.1 Manufacturer's drawings and installation instructions.

6.2 Testing and engineering analysis demonstrating compliance with the following codes and standards:

6.2.1 *Acceptance Criteria for Translucent Fiberglass Reinforced Plastic (FRP) Faced Panel Wall, Roof and Skylight Systems (AC177)*, revised April 2017.

6.2.2 *Acceptance Criteria for Sandwich Panel Adhesives (AC05)*, revised July 2015.

6.2.3 Transverse load tests in accordance with ASTM E 72-05, *Standard Test Method of Conducting Strength Tests of Panels for Building Construction*.

6.2.4 Fire testing in accordance with UL 723-08, *Standard for Test for Surface Burning Characteristics of Building Materials*.

6.2.5 Flexural testing for determination of Thermally Broken I-beam structural properties.

6.2.6 Concentrated Static testing in accordance with ASTM E 661-88(1997), *Test Method for Performance for Wood and Wood-Based Floor and Roof Sheathing Under Concentrated Static and Impact Loads*.

6.2.7 Tensile testing in accordance with ASTM D 638-03, *Standard Test Method for Tensile Properties of Plastics*.

6.2.8 Air infiltration testing in accordance with ASTM E 283, *Test Method for Determining the Rate of Air Leakage Through Exterior Windows, Curtain Walls, and Doors Under Specified Pressure Differences Across the Specimen*.

6.2.9 Fire testing of roof coverings in accordance with UL 790-04, *Standard Test Methods for Fire Tests of Roof Coverings*.

6.2.10 Temperature Cycling testing in accordance with AC177 Section 4.9.

6.2.11 Water penetration testing in accordance with ASTM E 547, *Test Method for Water*

*Penetration of Exterior Windows, Skylights, Doors and Curtain Walls, and Doors Under Specified Pressure Differences Across the Specimen.*

6.3 Documentation of an Intertek approved quality control system for the manufacturing of products recognized in this report.

### **7. Conditions of Use**

The *Kalwall* Translucent Sandwich Panels identified in this report are deemed to comply with the referenced building codes for the use indicated subject to the following conditions.

7.1 The design and details of the *Kalwall* Translucent Sandwich Panel installation must be submitted to and approved by the code official for each project. Minimum bearing for Integral stiffener members shall be designed in accordance with the Aluminum Design Manual, ADM1-15.

7.2 Calculations for designs requiring load combinations must be submitted to and approved by the code official for each project.

7.3 Calculations for designs requiring the inclusion of collateral loads must be submitted to and approved by the code official for each project.

7.4 Where required by the building official, calculations shall be prepared and sealed by a licensed design professional according to the requirements in the jurisdiction where the project is located.

7.5 Panel design capacities, as noted in Table 2, shall not be exceeded. No diaphragm values are assigned to the panels.

7.6 Evaluation for the use of *Kalwall* Translucent Sandwich Panels as a component of a fire-resistant rated wall assembly is not within the scope of this report.

7.7 Insulbar® support is limited to negative windload in roof panel applications.

7.8 For roof panels, water accumulation or water ponding shall be addressed in accordance with Footnote e of IBC Table 1604.3.

7.9 *Kalwall* Translucent Sandwich Panel's roof installation for compliance with the IBC shall be in accordance with IBC Section 2609 through item 3 of 2609.1.

7.10 Fiberglass Reinforced Plastic (FRP) sheets are manufactured under an approved quality control system with inspections by Underwriters Laboratory (AA-668)

7.11 Classified roof panels in accordance with IBC Section 1505 are manufactured under an approved quality control system with follow-up inspections by Underwriters Laboratory (AA-668)

7.12 The *Kalwall* Translucent Sandwich Panels identified in this report are manufactured in Manchester, New Hampshire under an approved quality control system with inspections by Architectural Testing (IAS AA-676).

### **8. Identification**

*Kalwall* Translucent Sandwich Panels produced in accordance with this report shall be identified with permanent labeling that includes the following information:

8.1 Name and/or trademark of manufacturer, *Kalwall* Corporation.

8.2 The part number.

8.3 The thickness and plastic classification (CC1 or CC2) of each facing.

8.4 The identification of the exterior FRP face.

8.5 For roof panels, the roof covering classification.

8.6 Interior finish (surface burning) classification (Class A, B or C)

8.7 The Architectural Testing Code Compliance Research Report mark and number (CCRR-0173)

### **9. Code Compliance Research Report Use**

9.1 Approval of building products and/or materials can only be granted by a building official having legal authority in the specific jurisdiction where approval is sought.

9.2 Code Compliance Research Reports shall not be used in any manner that implies an endorsement of the product or manufacturer by Architectural Testing.

9.3 Reference to the Architectural Testing internet web site address at [www.ati-es.com](http://www.ati-es.com) is recommended to ascertain the current version and status of this report.

**Table 1 - Fiberglass Reinforced Plastic Sheet Types**

FRP Face Sheet Types <sup>3</sup>		Thickness (inch)	Plastic Combustibility Classification <sup>1</sup>	Surface Burning Classification (UL 723)	Roof Fire Classification (UL 790) <sup>2,4</sup>
Interior Sheets	Type S-171	0.045	CC1	Class B	N.A.
	Type 25	0.045	CC1	Class A	N.A.
	Type B-3A	0.045	CC1	Class A	N.A.
Exterior Sheets	Type SW	0.070	CC2	Class C	N.A.
	Type SW-C	0.070	CC1	Class B	Class A
	Type A	0.070	CC1	Class A	Class A

<sup>1</sup>IBC Section 2606.4

<sup>2</sup>Roof fire classification is for the face sheet type when used in a classified roof panel assembly. See UL listing for complete description of the classified roof panel assembly.

<sup>3</sup>In special cases (e.g. screen wall, partition, canopy) panels may have either interior sheets or exterior sheets installed on both faces to meet code or performance requirements, with the limitation that interior sheets shall not be exposed to exterior conditions.

<sup>4</sup>Aluminum I-Beam panels may or may not include fiberglass insulation. Fiberglass insulation is required for Thermally Broken I-Beam panels. The fiberglass insulation is either DRAH-type with a nominal density of 0.5 pound per cubic foot or RAH-type with a nominal density of 0.27 pound per cubic foot.

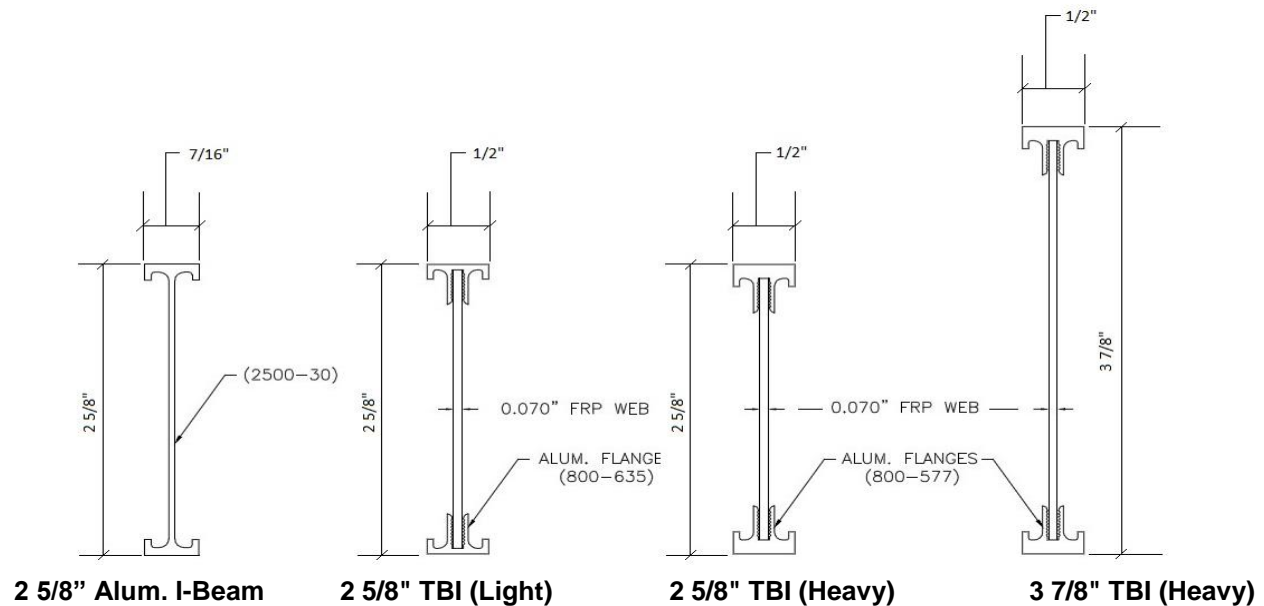
**Figure 1: Grid-Core I-Beams**

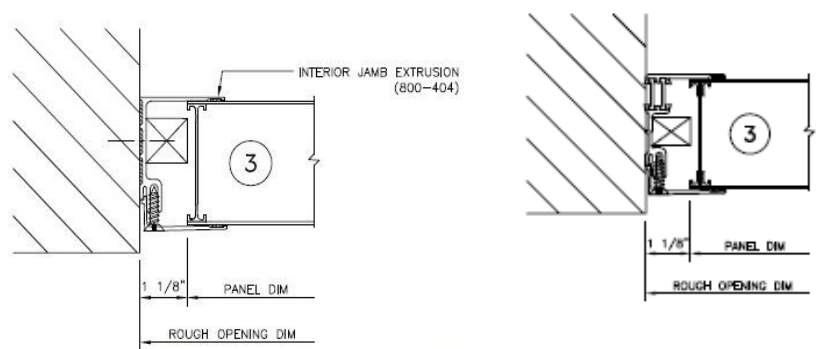
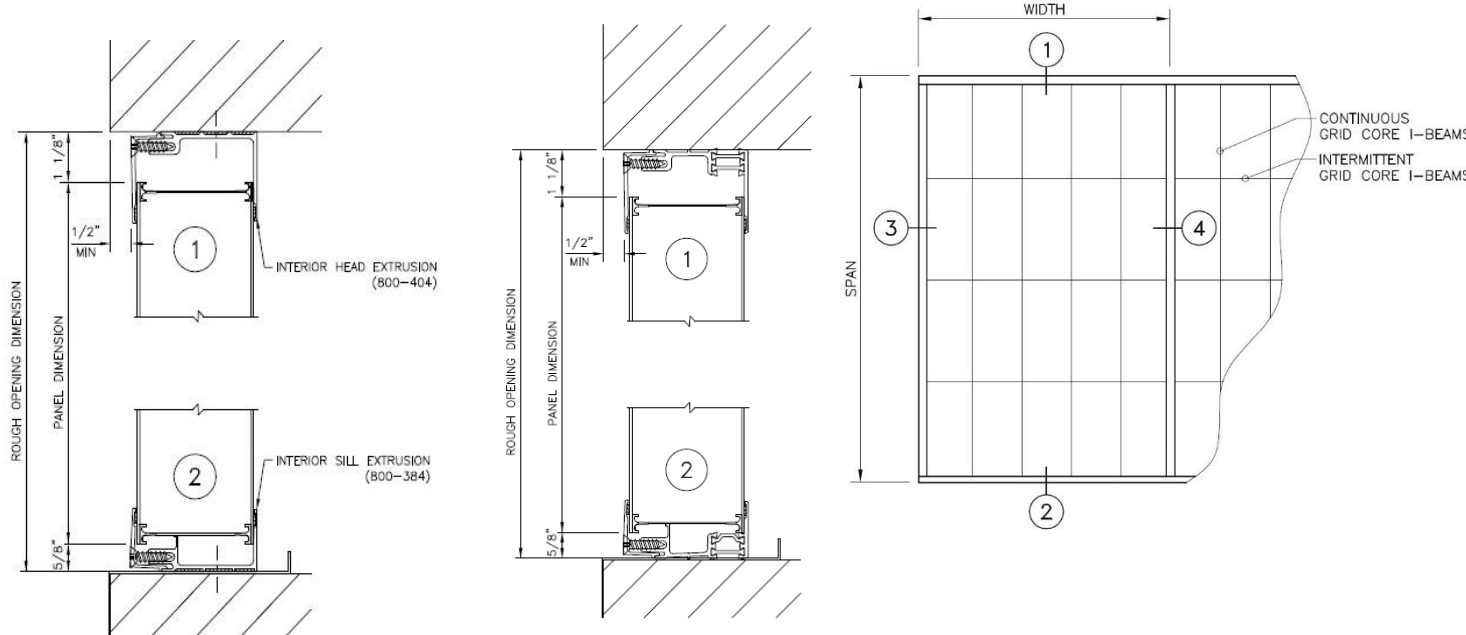
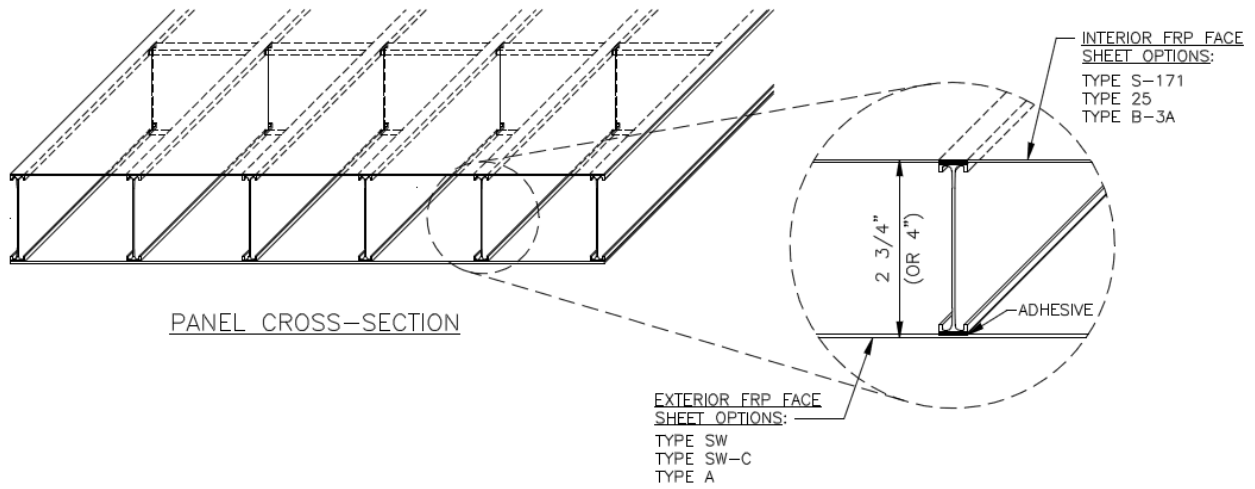
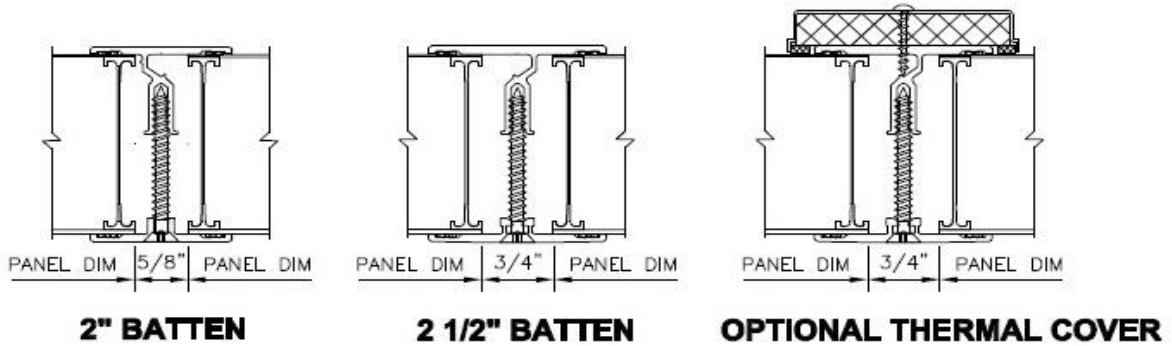

Figure 2: Longitudinal Grid-Core Framing- Wall Panels

4 WALL BATTEN OPTIONS



4 ROOF BATTEN OPTIONS

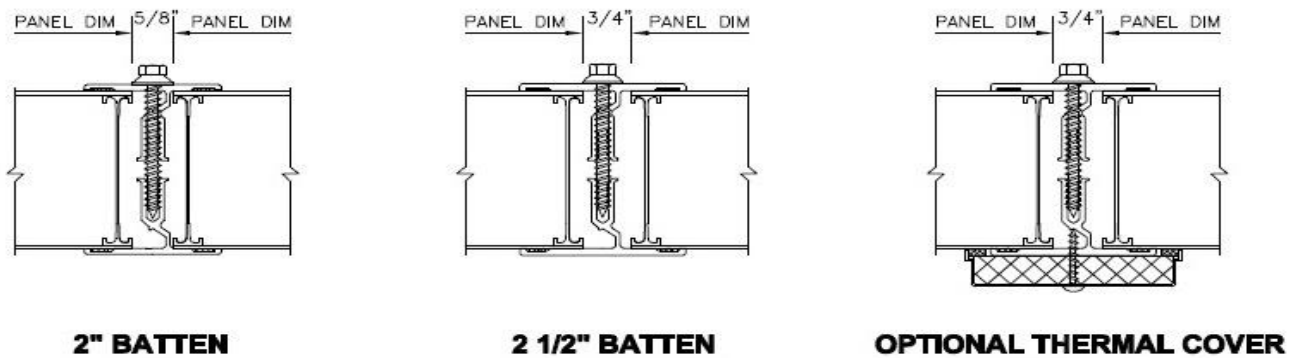

Figure 3: Wall and Roof Batten Options

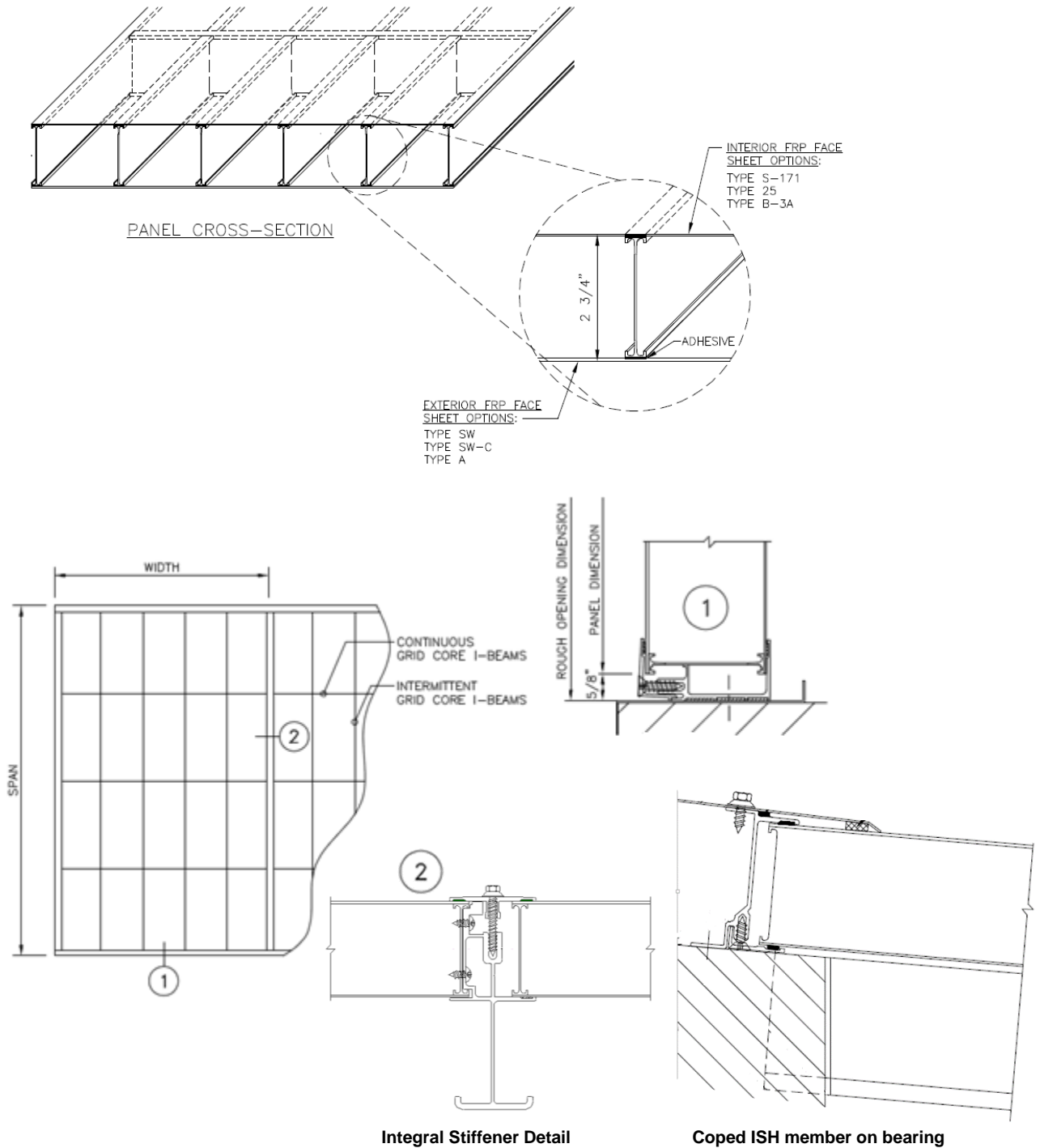

Figure 4: Transverse Grid-Core Framing with Integral Stiffener (ISH) – Wall and Roof Panels

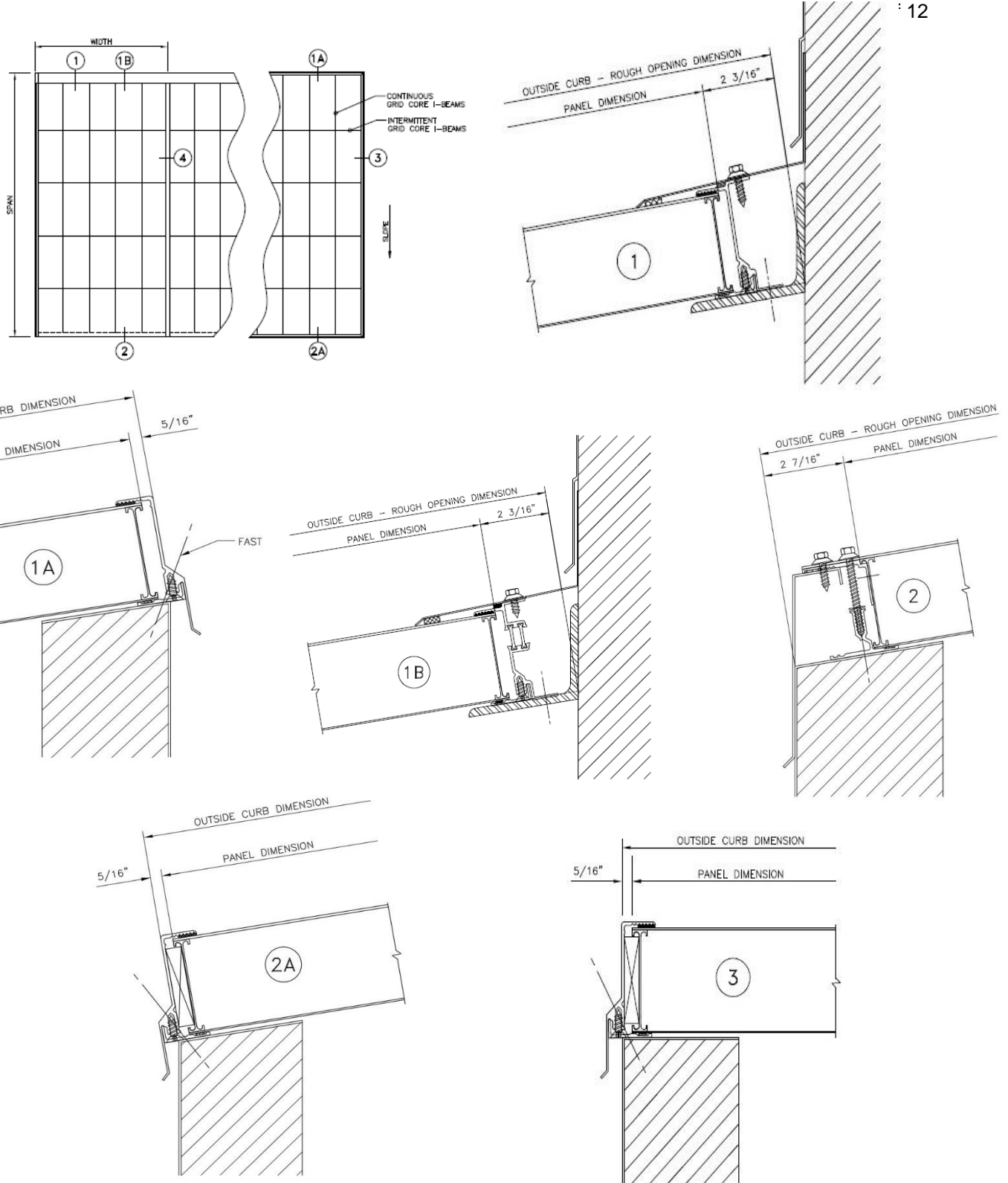

Figure 5: Longitudinal Grid-Core Framing with Battens – Roof Panels

**Table 2 - 4' Wide Longitudinal Grid Panel Capacities**

I-Beam	Shear Strength Max Shear (lbs)		Bending Strength Max Moment (ft-lbs)		Panel Stiffness Equiv. EI (x10 <sup>6</sup> lbs-in <sup>2</sup> )	
	12" x 24"	8" x 20"	12" x 24"	8" x 20"	12" x 24"	8" x 20"
2 5/8" Alum. I-Beam	5,750	8,050	1,148	1,607	9.27	12.98
2 5/8" TBI (Light)	765	1,070	1,002	1,403	8.10	11.34
2 5/8" TBI (Heavy)	890	1,181	1,361	1,905	11.00	15.40
3 7/8" TBI (Heavy)	730	1,020	2,393	3,350	28.55	39.97

**Table 3 - Nominal Grid-Core Module Configurations**

Panel Grid-Core Module		Grid-Core I-Beam Spacing		Continuous I-Beam Span	3 1/4" Integral Heavy Stiffener (ISH) Span
		Continuous	Intermittent		
Longitudinal Grid (Fig. 2)	12" x 24"	12" O.C.	24" O.C.	Panel Length (See Span Tables)	N/A
	8" x 20"	8" O.C.	20" O.C.		
Transverse Grid with ISH (Fig. 3)	12" x 24"	24" O.C.	12" O.C.	Panel Width (4 Ft.)	Panel Length <sup>1</sup> (See Span Tables)
	24" x 12"	12" O.C.	24" O.C.		

<sup>1</sup>Allowable spans for transverse grid-core panels with external supports are greater than transverse grid-core panels with ISH supports.

**ROOF SPAN TABLES – 4' Wide Panels**

Maximum allowable spans include a panel dead load of 2 psf and 3 psf for 2 3/4" and 4" nominal panels respectively.

\* Panel deflections for wind load are taken at 0.7 times the tabulated loads in accordance with IBC Table 1604.3, note f.

\*\* Limited by 300 lb concentrated live load per IBC 1607.4

**Table 4 – 2 3/4" Aluminum I-Beam Maximum Roof Spans (2:12 Minimum Roof Pitch)**

Grid Orientation	Grid Size	Live Load (L/60)						
		20 PSF	30 PSF	40 PSF	50 PSF	60 PSF	70 PSF	80 PSF
Longitudinal Grid (Fig. 2)	12" x 24"	8'-4"***	8'-4"***	7'-6"	6'-9"	6'-2"	5'-9"	5'-4"
	8" x 20"	10'-10"***	9'-9"	8'-10"	8'-0"	7'-4"	6'-9"	6'-4"
4 ft. Panel Transverse Grid with ISH (Fig. 3)	12" x 24"	19'-10"	16'-5"	14'-4"	12'-11"	-	-	-
	24" x 12"	19'-10"	16'-5"	14'-4"	12'-11"	11'-10"	10'-11"	10'-3"
Grid Orientation	Grid Size	Wind Load (L/60)*						
		20 PSF	30 PSF	40 PSF	50 PSF	60 PSF	70 PSF	80 PSF
Longitudinal Grid (Fig. 2)	12" x 24"	10'-9"	8'-9"	7'-7"	6'-9"	6'-2"	5'-9"	5'-4"
	8" x 20"	12'-8"	10'-4"	9'-0"	8'-0"	7'-4"	6'-9"	6'-4"
4 ft. Panel Transverse Grid with ISH (Fig. 3)	12" x 24"	20'-6"	16'-9"	14'-6"	13'-0"	-	-	-
	24" x 12"	20'-6"	16'-9"	14'-6"	13'-0"	11'-10"	10'-11"	10'-3"

**ROOF SPAN TABLES – 4' Wide Panels (Cont'd)**

Maximum allowable spans include a panel dead load of 2 psf and 3 psf for 3" and 4" nominal panels respectively.

\* Panel deflections for wind load are taken at 0.7 times the tabulated loads in accordance with IBC Table 1604.3, note f.

\*\* Limited by 300 lb concentrated live load per IBC 1607.4

**Table 5 – 2 3/4" TBI (Light) Maximum Roof Spans (2:12 Minimum Roof Pitch)**

Grid Orientation	Grid Size	Live Load (L/60)						
		20 PSF	30 PSF	40 PSF	50 PSF	60 PSF	70 PSF	80 PSF
Longitudinal Grid (Fig. 2)	12" x 24"	7'-5"***	7'-5"***	7'-0"	6'-4"	5'-9"	-	-
	8" x 20"	10'-2"***	9'-4"	8'-3"	7'-5"	6'-10"	-	-
Transverse Grid with ISH (Fig. 3) 4 ft. Panel Width	12" x 24"	19'-10"	16'-5"	14'-4"	-	-	-	-
	24" x 12"	19'-10"	16'-5"	14'-4"	12'-11"	11'-10"	10'-11"	10'-3"
Grid Orientation	Grid Size	Wind Load (L/60)*						
		20 PSF	30 PSF	40 PSF	50 PSF	60 PSF	70 PSF	80 PSF
Longitudinal Grid (Fig. 2)	12" x 24"	10'-0"	8'-2"	7'-1"	6'-4"	5'-9"	-	-
	8" x 20"	11'-10"	9'-8"	8'-4"	7'-6"	6'-10"	-	-
Transverse Grid with ISH (Fig. 3) 4 ft. Panel Width	12" x 24"	20'-6"	16'-9"	14'-6"	-	-	-	-
	24" x 12"	20'-6"	16'-9"	14'-6"	13'-0"	11'-10"	10'-11"	10'-3"

**Table 6 – 2 3/4" TBI (Heavy) Maximum Roof Spans (2:12 Minimum Roof Pitch)**

Grid Orientation	Grid Size	Live Load (L/60)						
		20 PSF	30 PSF	40 PSF	50 PSF	60 PSF	70 PSF	80 PSF
Longitudinal Grid (Fig. 2)	12" x 24"	9'-6"	9'-3"	8'-2"	7'-4"	6'-9"	-	-
	8" x 20"	11'-8"	10'-4"	9'-5"	8'-8"	7'-11"	-	-
Transverse Grid with ISH (Fig. 3) 4 ft. Panel Width	12" x 24"	19'-10"	16'-5"	14'-4"	12'-11"	-	-	-
	24" x 12"	19'-10"	16'-5"	14'-4"	12'-11"	11'-10"	10'-11"	10'-3"
Grid Orientation	Grid Size	Wind Load (L/60)*						
		20 PSF	30 PSF	40 PSF	50 PSF	60 PSF	70 PSF	80 PSF
Longitudinal Grid (Fig. 2)	12" x 24"	11'-8"	9'-6"	8'-3"	7'-5"	6'-9"	-	-
	8" x 20"	13'-6"	11'-3"	9'-9"	8'-9"	8'-0"	7'-5"	6'-11"
Transverse Grid with ISH (Fig. 3) 4 ft. Panel Width	12" x 24"	20'-6"	16'-9"	14'-6"	13'-0"	-	-	-
	24" x 12"	20'-6"	16'-9"	14'-6"	13'-0"	11'-10"	10'-11"	10'-3"

**Table 7 – 4" TBI (Heavy) Maximum Roof Spans (2:12 Minimum Roof Pitch)**

Grid Orientation	Grid Size	Live Load (L/60)						
		20 PSF	30 PSF	40 PSF	50 PSF	60 PSF	70 PSF	80 PSF
Longitudinal Grid (Fig. 2)	12" x 24"	14'-2"	11'-4"	8'-9"	7'-1"	5'-11"	-	-
	8" x 20"	15'-10"	14'-0"	12'-2"	9'-11"	8'-4"	-	-
Grid Orientation	Grid Size	Wind Load (L/60)*						
		20 PSF	30 PSF	40 PSF	50 PSF	60 PSF	70 PSF	80 PSF
Longitudinal Grid (Fig. 2)	12" x 24"	15'-6"	12'-2"	9'-2"	7'-4"	6'-1"	-	-
	8" x 20"	18'-4"	14'-11"	12'-9"	10'-3"	8'-6"	-	-

**WALL SPAN TABLES – 4' Wide Panels**

\* Panel deflections for wind load are taken at 0.7 times the tabulated loads in accordance with IBC Table 1604.3, note f.

**Table 8 - 2 3/4" Aluminum I-Beam Maximum Wall Spans**

Grid Orientation	Grid Size	Wind Load (L/120)*						
		20 PSF	30 PSF	40 PSF	50 PSF	60 PSF	70 PSF	80 PSF
Longitudinal Grid (Fig. 2)	12" x 24"	9'-0"	7'-11"	7'-2"	6'-8"	6'-2"	5'-9"	5'-4"
	8" x 20"	10'-1"	8'-10"	8'-0"	7'-5"	7'-0"	6'-8"	6'-4"
Transverse Grid with ISH (Fig. 3) 4 ft. Panel Width	12" x 24"	18'-4"	16'-0"	14'-6"	13'-0"	-	-	-
	24" x 12"	18'-4"	16'-0"	14'-6"	13'-0"	11'-10"	10'-11"	10'-3"



**Table 9 - 2 3/4" TBI (Light) Maximum Wall Spans**

Grid Orientation	Grid Size	Wind Load (L/120)*						
		20 PSF	30 PSF	40 PSF	50 PSF	60 PSF	70 PSF	80 PSF
Longitudinal Grid (Fig. 2)	12" x 24"	8'-8"	7'-6"	6'-10"	6'-4"	5'-9"	-	-
	8" x 20"	9'-8"	8'-5"	7'-8"	7'-1"	6'-8"	-	-
Transverse Grid with ISH (Fig. 3) 4 ft. Panel Width	12" x 24"	18'-0"	15'-8"	14'-2"	-	-	-	-
	24" x 12"	18'-0"	15'-8"	14'-2"	13'-0"	11'-10"	10'-11"	10'-3"

**Table 10 - 2 3/4" TBI (Heavy) Maximum Wall Spans**

Grid Orientation	Grid Size	Wind Load (L/120)*						
		20 PSF	30 PSF	40 PSF	50 PSF	60 PSF	70 PSF	80 PSF
Longitudinal Grid (Fig. 2)	12" x 24"	9'-7"	8'-4"	7'-7"	7'-1"	6'-8"	-	-
	8" x 20"	10'-8"	9'-4"	8'-6"	7'-11"	7'-5"	-	-
Transverse Grid with ISH (Fig. 3) 4 ft. Panel Width	12" x 24"	18'-4"	16'-0"	14'-6"	13'-0"	-	-	-
	24" x 12"	18'-4"	16'-0"	14'-6"	13'-0"	11'-10"	10'-11"	10'-3"

**Table 11 - 4" TBI (Heavy) Maximum Wall Spans**

Grid Orientation	Grid Size	Wind Load (L/120)*						
		20 PSF	30 PSF	40 PSF	50 PSF	60 PSF	70 PSF	80 PSF
Longitudinal Grid (Fig. 2)	12" x 24"	13'-2"	11'-6"	9'-2"	7'-4"	6'-1"	-	-
	8" x 20"	14'-8"	12'-10"	11'-8"	10'-3"	8'-6"	-	-

**Table 12 – Maximum Height for Interior Non-Load Bearing Partitions**

Grid-Core Framing <sup>1</sup>	Grid Size	Uniform Transverse Load ( Deflection ≤ L/120)		
		5 PSF	7.5 PSF	10 PSF
2 3/4" Aluminum I-Beam	12" x 24"	12'-9"	11'-1"	10'-1"
	8" x 20"	14'-3"	12'-5"	11'-4"

<sup>1</sup>Longitudinal grid-core framing (Fig. 2)