

**DIVISION: 09 00 00 – FINISHES**  
**Section: 09 22 36 –Lath**

**BASF CORPORATION**  
3550 ST. JOHNS BLUFF ROAD SOUTH  
JACKSONVILLE, FLORIDA 32224  
(904) 996-6000  
[www.wallsystems.basf.com](http://www.wallsystems.basf.com)

**REPORT SUBJECT:**  
**PERMALATH® 1000 GLASS FIBER LATH**

### 1.0 SCOPE OF EVALUATION

This research report addresses compliance with the following Codes:

- 2015, 2012 International Building Code (IBC)
- 2015, 2012 International Residential Code (IRC)
- 2014 Florida Building Code (see Section 8.0)

The PermaLath® 1000 Glass Fiber Lath has been evaluated for the following properties:

- Wind resistance
- Durability
- Fire resistance
- Noncombustibility
- Use in Types I, II, III and IV construction

See Table 1 for applicable Code sections related to these properties.

NOTE: This report references 2012 Code sections with [2009] Code sections shown in brackets where they differ.

### 2.0 USES

PermaLath® 1000 is used as reinforcement for exterior cement plaster, BASF StuccoBase cementitious wall covering, SPEC MIX FIBER BASE COAT (FBC), or exterior cement plaster supporting precast stone veneer.

### 3.0 DESCRIPTION

#### 3.1. PermaLath® 1000:

PermaLath® 1000 is an open-weave, three dimensional lath, formed from glass fibers. PermaLath® 1000 has a nominal thickness of 1/4 inch, weighs 8.8 oz/yard<sup>2</sup> and is supplied in 39 inch wide by 150 foot long rolls.

#### 3.2. Exterior Wall Coverings:

This report recognizes use of PermaLath® 1000 lath with the following exterior wall coverings:

- BASF StuccoBase cementitious wall covering recognized in CCRR-0230;
- SPEC MIX FIBER BASE COAT (FBC) cementitious wall covering recognized in CCRR-0231;
- Exterior cement plaster supporting precast stone veneer recognized in a current research or evaluation report as complying with ICC-ES AC51 and;
- Exterior cement plaster (stucco) conforming to ASTM C926.

#### 3.3. Substrates:

Substrates must be:

- Minimum 7/16 inch thick, Exposure 1, oriented strand board (OSB) complying with U.S. DOC PS-2;
- Minimum 7/16 inch thick, Exterior or Exposure 1 plywood complying with U.S. DOC PS-1 or PS-2; or
- Minimum 1/2 inch thick water resistant core gypsum sheathing board complying with ASTM C1396 or ASTM C1177.

### 4.0 INSTALLATION

#### 4.1. General:

The lath must be installed with a minimum 3 inch overlap at vertical and horizontal edges and must overlap over the flange of trim accessories. The lath



must be applied flat and must be free of ripples, wrinkles, etc.

The lath must be attached as described in Tables 2 and 3.

Exterior cement plaster must be proportioned, mixed, and installed in accordance with ASTM C926, and must have a minimum thickness of 3/4 inch.

StuccoBase and SPEC MIX FIBER BASE COAT (FBC) exterior wall coverings must be installed in accordance with the applicable evaluation report and as follows:

- The coating must have a minimum thickness of 1/2 inch.
- Installation is limited to the assemblies described in this report.

Precast stone veneer must be recognized in a current evaluation report as complying with ICC-ES AC51, where the PermaLath® 1000 is permitted in lieu of metal lath.

#### 4.2. Resistance to Windloads:

The maximum allowable positive and negative wind loads on exterior wall systems incorporating PermaLath® 1000 glass fiber lath are noted in Table 2.

#### 4.3. One-hour Fire-resistance-rated Wall Assemblies:

Fire-resistance-rated wall assemblies incorporating PermaLath® 1000 lath must conform with the assemblies described in Tables 3 and 4.

#### 4.4. Exterior Walls in Types I, II, III and IV Construction:

**4.4.1. Assemblies Without Foam Plastic Insulation:** PermaLath® 1000 embedded into exterior cement plaster complying with the code, BASF StuccoBase cementitious exterior wall coating or SPEC MIX FIBER BASE COAT (FBC) cementitious exterior wall coating is considered noncombustible in accordance with Section 703.5 of the IBC.

**4.4.2. Assemblies Incorporating Foam Plastic Insulation:** Assemblies incorporating foam plastic insulation must be as described in Table 5.

## 5.0 CONDITIONS OF USE

The PermaLath® 1000 glass fiber lath described in this Research Report complies with, or is a suitable alternative to, what is specified in those Codes listed in Section 1.0 of this report, subject to the following conditions:

**5.1.** Installation must comply with this Research Report, the manufacturer's published installation instructions and the applicable Code. In the event of a conflict between the manufacturer's instructions and this report, this report governs.

**5.2.** Design loads for the exterior wall covering systems described in this report must be determined in accordance with the applicable code and must not exceed the allowable wind loads described in Table 2 of this report. The framing and sheathing must be designed and installed in accordance with the applicable code.

**5.3.** Use in one-hour fire-resistance-rated wall assemblies must be as described in Section 4.3 and Table 3.

**5.4.** Use on exterior walls of Type I, II, III or IV construction must be as described in Section 4.4 and Table 4.

**5.5.** When used as a component of a precast stone veneer system, use of the PermaLath® 1000 glass fiber lath must be acceptable to the manufacturer of the precast stone veneer system.

**5.6.** The lath is manufactured under a quality control program with inspections by Intertek Testing Services NA, Inc. (AA-647).

## 6.0 SUPPORTING EVIDENCE

**6.1.** Reports of tests in accordance with ASTM E119-12a, ASTM E136-12, NFPA 268-12, NFPA 285-12.

**6.2.** Data in accordance with the ICC-ES AC275, *Acceptance Criteria for Glass Fiber Lath Used in Cementitious Exterior Wall Coatings or Exterior Cement Plaster (Stucco)*.

**6.3.** Third-party engineering analysis of ASTM E119 and NFPA 285 assemblies.



Intertek

130 Derry Court • York • Pennsylvania • 17406

[intertek.com/building](http://intertek.com/building)



ACCREDITED

Product  
Certification Agency

PCA-125



## 7.0 IDENTIFICATION

Each roll of PermaLath® 1000 is identified by a label bearing the company name (BASF Corporation), roll dimensions, the Intertek Mark as shown below, and the Code Compliance Research Report number (CCRR-0249).



## 8.0 FLORIDA BUILDING CODE

### 8.1. Scope of Evaluation:

PermaLath® 1000 glass fiber lath was evaluated for compliance with the 2014 *Florida Building Code – Building and Florida Building Code – Residential*.

### 8.2. Conclusion:

BASF PermaLath® 1000 glass fiber lath, described in Sections 2.0 through 7.0 of this Research

## 10.0

Report, complies with the 2014 *Florida Building Code – Building and Florida Building Code – Residential*, subject to the following conditions:

- Use of PermaLath® 1000 glass fiber lath for compliance with the High-Velocity Hurricane Zone provisions of the 2014 *Florida Building Code – Building and the Florida Building Code – Residential* has not been evaluated, and is outside the scope of this Research Report.
- Intertek is a quality assurance entity approved by the Florida Building Commission.

## 9.0 CODE COMPLIANCE RESEARCH REPORT USE

**9.1.** Approval of building products and/or materials can only be granted by a building official having legal authority in the specific jurisdiction where approval is sought.

**9.2.** Code Compliance Research Reports shall not be used in any manner that implies an endorsement of the product by Intertek.

**9.3.** Reference to the Intertek website address: [whdirectory.intertek.com](http://whdirectory.intertek.com) is recommended to ascertain the current version and status of this report.

This Code Compliance Research Report ("Report") is for the exclusive use of Intertek's Client and is provided pursuant to the agreement between Intertek and its Client. Intertek's responsibility and liability are limited to the terms and conditions of the agreement. Intertek assumes no liability to any party, other than to the Client in accordance with the agreement, for any loss, expense or damage occasioned by the use of this Report. Only the Client is authorized to permit copying or distribution of this Report and then only in its entirety, and the Client shall not use the Report in a misleading manner. Client further agrees and understands that reliance upon the Report is limited to the representations made therein. The Report is not an endorsement or recommendation for use of the subject and/or product described herein. This Report is not the Intertek Listing Report covering the subject product and utilized for Intertek Certification and this Report does not represent authorization for the use of any Intertek certification marks. Any use of the Intertek name or one of its marks for the sale or advertisement of the tested material, product or service must first be approved in writing by Intertek.



**TABLE 1 – PROPERTIES EVALUATED**

PROPERTY	IBC	IRC
Wind resistance	104.11, 1609	R301.2.1
Durability	104.11	104.11
Fire resistance	703.2	R302
Noncombustibility	703.5	Not applicable
Use on walls in Types I, II, III and IV construction	2603.5	Not applicable

**TABLE 2 – ALLOWABLE WIND LOADS**

FRAMING	SHEATHING <sup>1</sup>	LATH ATTACHMENT	EXTERIOR WALL COVERING	ALLOWABLE WIND LOADS (psf)	
				Positive	Negative
2 x 4 wood studs, min. 0.42 specific gravity, max. 16 " o.c.	Min. 7/16 in. OSB or 7/16 in. plywood	3/4 in. crown x 1-1/4 in., No. 16 ga. staples, spaced at 6 in. o.c., fastened into framing	Exterior cement plaster complying with ASTM C926 – 3/4 in. thick	54	41
			StuccoBase or SPEC MIX – 1/2 in. thick	23	30
			Precast stone veneer <sup>2</sup>	Per the research report on the stone veneer	
No. 20 gage steel, max. 16 in. o.c.	Min. 1/2 in. gypsum sheathing	#6 x 1-1/4 in. Type S, 0.32-in-dia. head screws, Or 1-1/4 in. by 0.10-in. dia. VersaPIN Gripshank fasteners, With 1-1/4 in. Wind-Lock Lath Plates (legless), spaced 6 in. o.c., fastened into framing	Exterior cement plaster complying with ASTM C926 – 3/4 in. thick	51	21
			StuccoBase or SPEC MIX – 1/2 in. thick	23	21
			Precast stone veneer <sup>2</sup>	Per the research report on the stone veneer	

<sup>1</sup>Sheathing must comply with, and be installed in accordance with, the code

<sup>2</sup>Precast stone veneer must comply with ICC-ES AC51



Intertek

130 Derry Court • York • Pennsylvania • 17406

[intertek.com/building](http://intertek.com/building)

ACCREDITED

Product Certification Agency

PCA-125

**TABLE 3 – ONE-HOUR FIRE-RESISTANCE-RATED ASSEMBLIES WITHOUT FOAM PLASTIC INSULATION**

ASSEMBLY	INTERIOR	FRAMING	SHEATHING	LATH ATTACHMENT	COATING
Nonload Bearing	Min. 5/8 in. Type X gypsum sheathing installed vertically with #6 x 1 in., screws spaced 8 in. o.c. on perimeter and 12 in. o.c. on intermediate studs, joints must be backed by framing, joints and nail heads must be treated per ASTM C840 or GA216	Min. No. 20 gage steel, max. 16 in. o.c.	Min. 5/8 in. Type X gypsum sheathing installed horizontally with #6 x 1-1/4 in. screws spaced 8 in. o.c.; weather-resistive barrier applied over sheathing	PermaLath® 1000 attached per Table 2	StuccoBase or SPEC MIX – 1/2 in.
Nonload Bearing	Min. 5/8 in. Type X gypsum sheathing installed vertically with #6 x 1 in., screws spaced 8 in. o.c. on perimeter and 12 in. o.c. on intermediate studs, joints must be backed by framing, joints and nail heads must be treated per ASTM C840 or GA216	Min. No. 20 gage steel, max. 16 in. o.c.	Min. 5/8 in. Type X gypsum sheathing installed horizontally with #6 x 1-1/4 in. screws spaced 8 in. o.c.; weather-resistive barrier applied over sheathing	PermaLath® 1000 attached per Table 2	ASTM C926 – 3/4 in.
Limited Load Bearing <sup>1, 2</sup>	Min. 5/8 in. Type X gypsum sheathing installed vertically with 1-7/8 in., 0.0975 in. dia., cuphead drywall nails, spaced 8 in. o.c., joints must be backed; joints and nail heads must be treated per ASTM C840 or GA216	Min. 2 x 4 wood, max. 16 in. o.c., R-11 kraft-faced fiberglass in stud cavities	Min. 7/16 in. OSB installed horizontally with 6d sinker nails spaced at 8 in. o.c.; two layers of water-resistive barrier applied over sheathing per IBC Section 2510.6 or IRC Section R703.6	PermaLath® 1000 attached per Table 2	ASTM C926 – 3/4 in.

<sup>1</sup>Axial Design: Axial loads applied to the wall assembly shall be limited to the lesser of the following:

- a. 1,100 pounds per stud
- b. A maximum of 47.5% of the load calculated in accordance with Sections 3.6 and 3.7 of the ANSI/AF&PA NDS
- c. Design stress of  $0.78 F'_c$  calculated in accordance with Sections 3.6 and 3.7 of the NDS
- d. Design stress of  $0.78 F'_c$  calculated at a maximum  $l_e/d$  of 33 calculated in accordance with Sections 3.6 and 3.7 of the NDS

<sup>2</sup> Exterior walls shall have a minimum fire separation distance of 5 feet (1524 mm) in accordance with IBC Section 704.5



Intertek

130 Derry Court • York • Pennsylvania • 17406

intertek.com/building



ACCREDITED

Product Certification Agency

PCA-125

**TABLE 4 – ONE-HOUR NONLOAD-BEARING FIRE-RESISTANCE-RATED ASSEMBLIES INCORPORATING FOAM PLASTIC INSULATION**

WAL COMPONENT	MATERIALS
Interior gypsum board	Minimum 5/8-inch-thick Type X gypsum board complying with ASTM C1396, installed vertically and attached to framing using minimum #6 by 1-1/4 inch self-tapping drywall screws at 8 in. o.c. on top and bottom tracks and 12 in. o.c. on each stud. All joints and fasteners require a Level 2 finish
Steel framing	Minimum 3-5/8 inch deep, minimum No. 20 gage steel studs spaced a maximum of 24 in. o.c.
Wall cavity insulation – use 1, 2 or 3	1 – none 2 – fiberglass batt insulation (faced or unfaced) 3 – mineral wool insulation (faced or unfaced)
Exterior sheathing	Minimum 5/8-inch-thick Type X gypsum board complying with ASTM C1396 of ASTM C1177, installed vertically and attached to framing with No. 6 by 1-1/4 inch self-tapping screws spaced 8 in. o.c. around the perimeter and in the field.
Water-resistive barrier – use 1, 2, 3, 4 or 5	1 – one layer of No. 15 felt complying with ASTM D226, Type I 2 – Enershield-HP, Senershield-R, Finestop-RA, or Acrostop R – Enershield-I, Senershield-VB or Finestop-VB 4 – Grade D building paper recognized in a current evaluation report 5 – Tyvek Commercial Wrap (ICC-ES ESR-2375)
Continuous insulation – use 1 or 2	1 – expanded polystyrene (EPS) foam plastic insulation complying with ASTM C578, Type II, max. 2-1/2 inches thick 2 – BASF Neopor EPS insulation, recognized in ICCES ESR-3463, max 2-1/2 inches thick Insulation installed in running bond pattern and attached to framing with two #8 by 4 inch ITX Buildex screws and 1-1/4 inch diameter Wind-Lock Lath-Plate Fasteners (legless) (Part no. SP114WLF) (or equivalent) spaced 7 in. o.c.
Lath	PermaLath® 1000 glass fiber lath installed horizontally over insulation with minimum 3 inch overlaps at horizontal edges and attached to framing with #8 by 4 inch ITW Buildex screws and 1-1/4 in. Wind-Lock Lath-Plates (legless) (Part No. SP114WLF) (or equivalent), spaced 7 in. o.c.
Exterior wall covering	Minimum 1/2 inch thick StuccoBase or SPEC MIX
Finish	Any acrylic or cement-based finish or coating material applied over the stucco surface per manufacturer's instructions



Intertek

130 Derry Court • York • Pennsylvania • 17406  
intertek.com/building



ACCREDITED

Product  
Certification Agency

PCA-125



TABLE 5 – EXTERIOR WALLS IN TYPES I, II, III AND IV CONSTRUCTION

WALL COMPONENT	MATERIALS
Base wall system – use 1, 2 or 3	1 – concrete wall 2 – concrete masonry wall 3 – one layer of 1/2-inch thick regular or Type X gypsum board on interior, installed horizontally or vertically over minimum 3-5/8 inch, No. 20 gage steel framing spaced a maximum of 16 inches on center with lateral bracing every 4 feet vertically; gypsum board attached to framing with #6 by 1-1/4 self-drilling bugle-head screws spaced 8 in. o.c. on the perimeter and 12 in. o.c. in the field; joints and fasteners must have a Level 2 finish; framing for openings must be minimum No. 20 gage steel
Floorline firestopping	Min. 4 pcf mineral wool (e.g. Thermafiber) in each stud cavity at each floorline; attached with Z-clips or equivalent
Cavity insulation – use 1 or 2	1- none 2 – any noncombustible insulation (faced or unfaced)
Exterior sheathing	1/2- or 5/8-inch-thick exterior gypsum sheathing complying with ASTM C1396 or ASTM C1177; sheathing attached to framing with #6 by 1-14 self-drilling screws spaced at 8 in. o.c.
Air or water-resistive barrier applied over exterior sheathing	Any barrier described in Table 5B
Exterior insulation – use 1, 2, 3, 4, 5 or 6	1 – EPS, ASTM C578, Type II, max 2.5 inches (see note 1) 2 – EPS, ASTM C578, Type XI, max. 4.7 inches (see note 1) 3 – EPS, ASTM C578, Type IX, max. 1.8 inches (see note 1) 4 – BASF Neopor XPS, ASTM C578 Type II, max. 2.4 inches (see note 1) 5 – XPS, ASTM C578 Type X or Type IV (see notes 1 and 2) 6 – polyisocyanurate, ASTM C1289 (see notes 1 and 2)
Lath	BASF PermaLath® 1000 glass fiber lath applied horizontally with 3 inch overlaps at seams; attached to framing with #8 by 4 inch ITW Buildex screws and 1-1/4 in. Wind-Lock Lath-Plates (legless) (Part No. SP114WLF) (or equivalent), spaced 7 in. o.c.
Exterior wall covering – use 1 or 2	1 – BASF StuccoBase or SPEC MIX, min. 1/2 inch thick 2 – Stucco complying with ASTM C926, min. 3/4 inch thick
Finish – use 1 or 2	1 – Any BASF finish coating 2 – Any cementitious finish coating
Flashing of window, door and other exterior wall penetrations (optional)	Window, door and penetrations may be flashed with acrylic, asphalt or butyl-based flashing tape, max. 12 inches wide
Accessories – use 1 or 2 (see Figure 1)	1 – Galvanized steel, minimum 0.0172 inch thick 2 – PVC extrusions provided by BASF

Note 1 – Foam plastic insulation must be recognized in a current research report and must be have a flame-spread index and smoke-developed index of 25 or less and 450 or less, respectively.

Note 2 – The potential heat of the foam plastic insulation at the maximum installed thickness must not exceed 4999 Btu/ft<sup>2</sup>, as determined in accordance with NFPA 259.



Intertek

130 Derry Court • York • Pennsylvania • 17406

intertek.com/building



ACCREDITED

Product

Certification Agency

PCA-125



TABLE 5B – AIR AND WATER-RESISTIVE BARRIERS FOR USE IN ASSEMBLIES DESCRIBED IN TABLE 5A

Water-resistive Barrier – Over Sheathing
No. 15 Asphalt felt – ASTM D226, Type 1 – one layer
Enershield™-I - BASF
Senershield-VB - BASF
Finestop-VB - BASF
Enershield™-HP - BASF
Senershield-R - BASF
Finestop-RA - BASF
Acrostop R - BASF
Tyvek® StuccoWrap® - DuPont
WeatherMate™ or WeatherMate™Plus – Dow Chemical
CertaWrap™ - CertainTeed

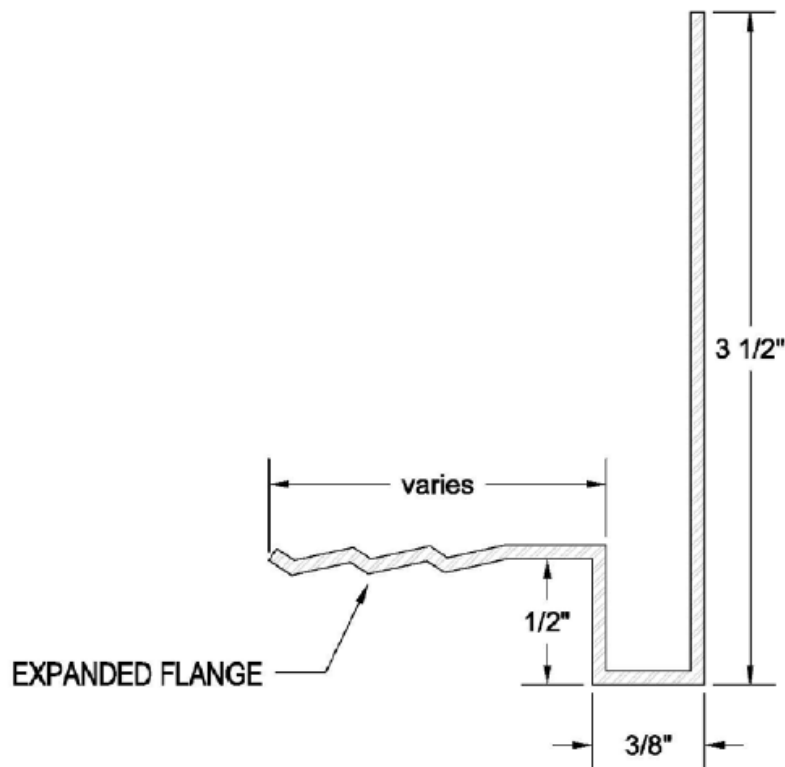



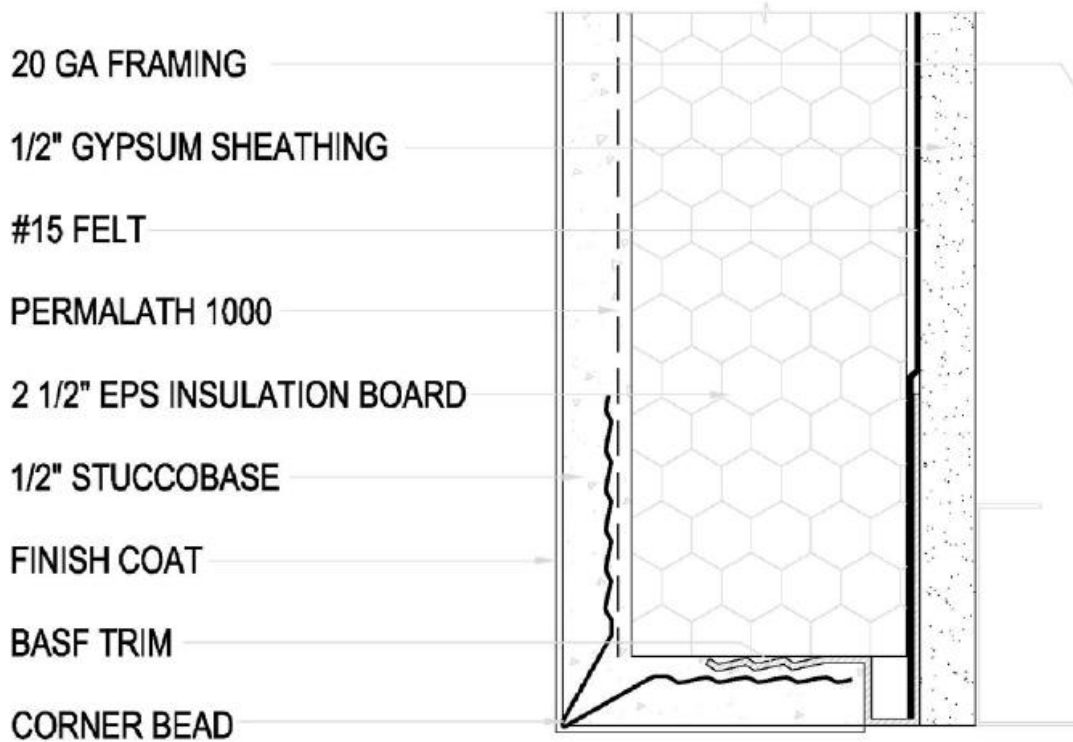

Figure 1 – Typical opening detail for NFPA 285 assembly (See Table 5)